



# BOOM TRUCK XCT60\_U

Less Flex, More Lift



60 USt



154 ft



137.8 ft



207.5 ft





# CONTENTS

Product Advantages and Highlights	01-04
Dimensions	05-07
Technical Specifications	08-09
Boom / Jib Combinations	10
Working Range Diagram and Load Charts	11-18
Working Areas and Reeving Diagram	19
Table of Main Technical Parameters	20-21
Description of Symbols	22-23



## WHERE IT COUNTS: THE BOOM

### THE LONGEST BOOM IN THE 60-TON CLASS.

- 39.4–154 ft full power five-section boom outreaches every 60-ton boom truck on the market.
- Optional fixed jib from 30.5–53.5 ft for extended reach when the job demands it.
- 0°, 15° and 30° jib offset angles.



### PRECISE HYDRAULICS | EFFICIENT PERFORMANCE

- Energy-saving, load sense hydraulic system for boom and winch functions.
- High-power hydraulic oil independent cooling system, promoting the working efficiency and reliability.
- Separate pumps for winch, boom and swing for interaction free multi function operation. Flows can be combined for higher speeds when needed.
- Free and braked swing modes for precise swing control.

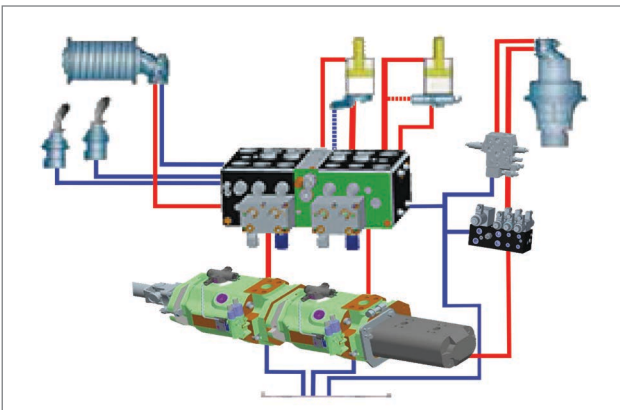

Precise hydraulic system

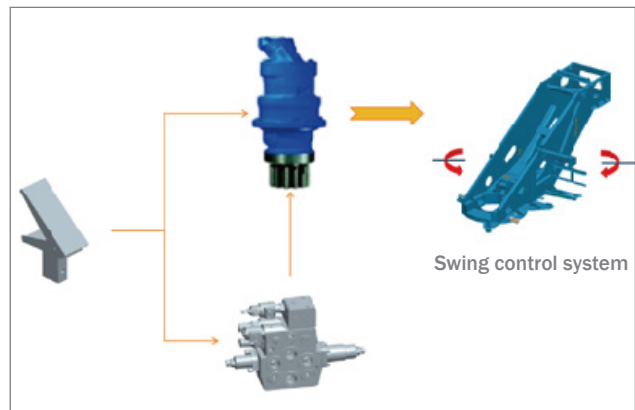

Foot pedal

## LOAD PLANNING

- LMI includes load chart lookup based on load, radius, and height.
- Simplified lift planning helps match crane configuration to load conditions.

Inf	OM	✓	All	<input type="checkbox"/>	Main boom	<input type="checkbox"/>	Fixed jib					
Balance weight	✓	All	<input type="checkbox"/>	7.26	<input type="checkbox"/>	5.81	<input type="checkbox"/>	4.35	<input type="checkbox"/>	2.9	<input type="checkbox"/>	1.45
Outrigger	✓	All	<input type="checkbox"/>	7.4	<input type="checkbox"/>	6.6	<input type="checkbox"/>	4.8	<input type="checkbox"/>	2.337		
Min Radius				<input type="text"/>				Weight		<input type="text"/>		
Max Radius				<input type="text"/>				Height		<input type="text"/>		
Res				Main boom				Fixed jib				

## REMOTE CONTROL

- Outrigger wireless remote control.
- Wireless remote control for main winch and boom luffing. The power switch on the subframe eliminates the need to climb into the cab for crane setup.
- Optional upper wireless remote control for all craning functions.

## BOOM TIP CAMERA

- Optional boom tip camera gives the operator a clear view of the load when line of sight is obstructed.



# HIGH WORKING EFFICIENCY, BETTER STABILITY

## PRECISE LIFTING OPERATION

- Dual load sense variable displacement pumps.
- Minimum stable winch speed 8.2 fpm, and minimum stable slewing speed 0.1 °/s.
- Hydraulic pilot operated controls for accurate and precise control.
- All this to optimize fine control along with providing strong and fast performance.

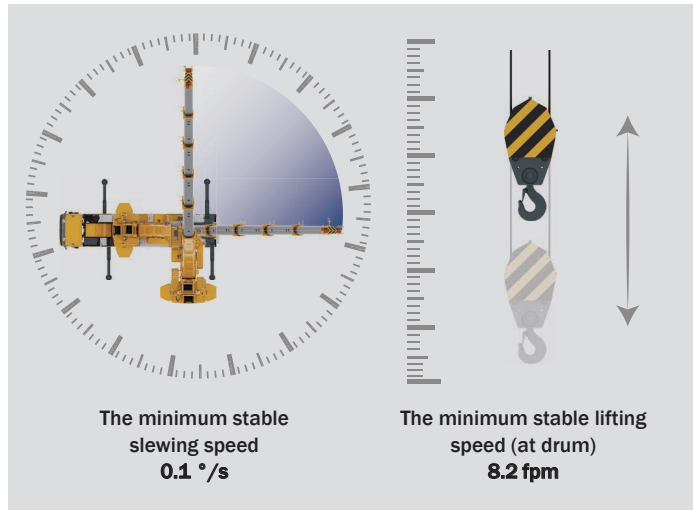

# COMFORT DRIVEN DESIGN



Redesigned driver and operator cab interiors put comfort and control where they should be, within reach. Every switch, sight line, and access point built around how operators actually work. Easier drives. Smoother operations. Faster maintenance.

Operator's Cab	0°–20° tiltable cab for wider visibility and a comfortable, purpose-built workspace.
Touchscreen	7-inch true-color touchscreen puts key information and machine intelligence at the operator's fingertips. Easy to learn, logical to anyone who's run a crane.
Zoned Controls	Three dedicated control zones for safety, lifting, and operating to keep everything within reach.

# DIMENSIONS

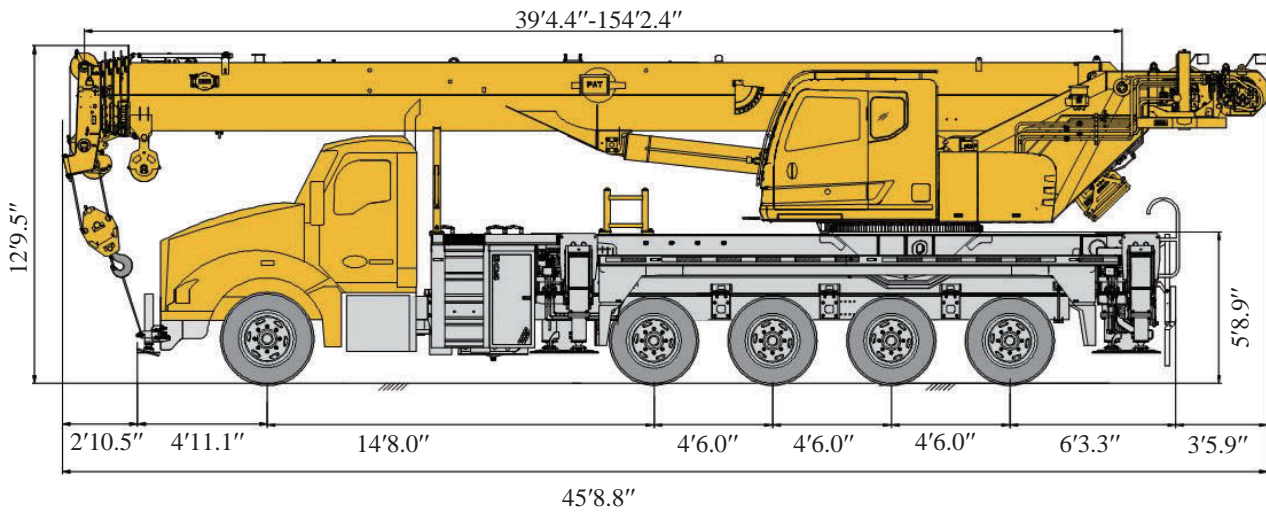

CHASSIS DATA	STEER AXLE GROSS WEIGHT RATING	PUSHER AXLE GROSS WEIGHT RATING	TRIDEM GROSS WEIGHT RATING
Weight	20,000 lb	13,220 lb	69,000 lb



HOOK BLOCK	NO. OF SHEAVES	PARTS OF LINE	WEIGHT	REMARKS
60 USt	6	12	1,232 lb	Single hook
40 USt	4	8	794 lb	Single hook
27.5 USt	3	6	598 lb	Single hook
15 USt	1	3	400 lb	Single hook
5.5 USt	—	1	220 lb	Single hook

Fully Extended Outriggers

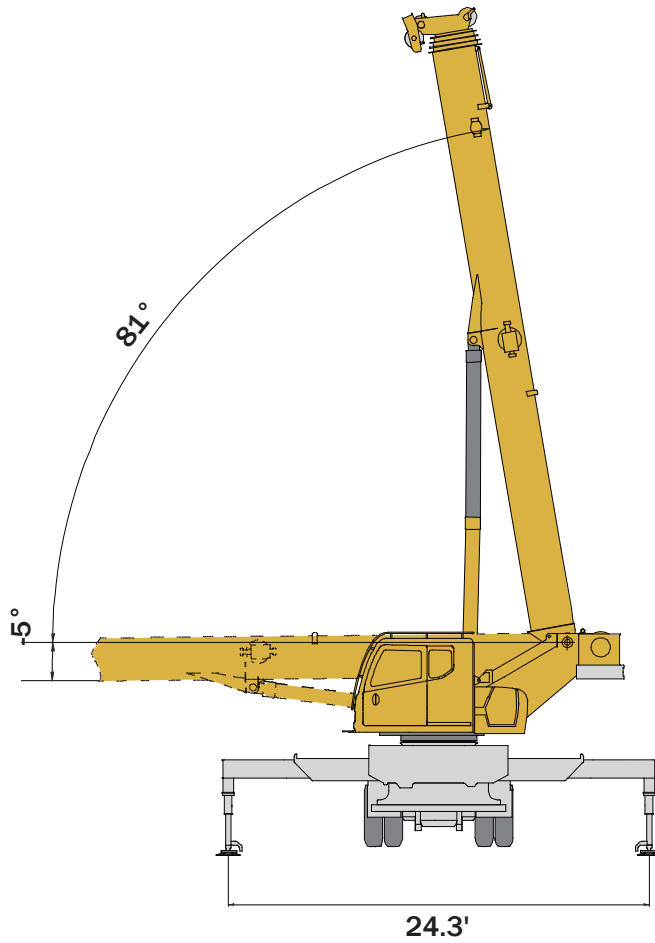

21.7' Span

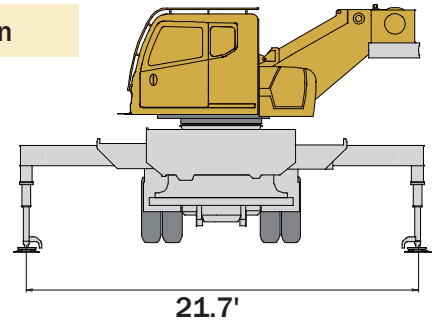



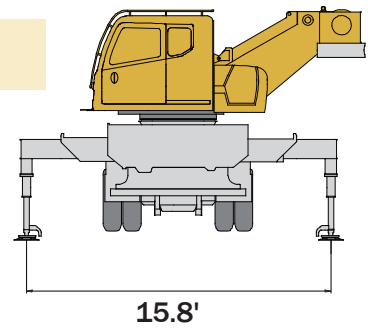



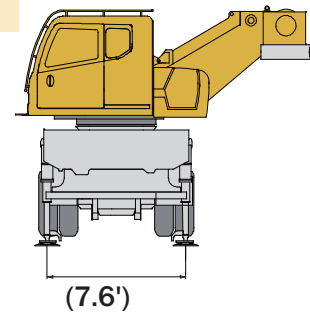

15.8' Span



7.6' Span



# WORKING SPEEDS

	 Max	 F
	0-394 fpm single line 4th layer	11,023 lb
	0-394 fpm single line 4th layer	11,023 lb
	0-1.2 rpm	
	Approximately 40s for boom luffing from -5° to 81°	
	Approximately 80s for boom extending from 39.4 ft to 154 ft	

<b>INTERMEDIATE FRAME</b>	
<b>Subframe</b>	Designed and manufactured by XCMG. Made of high strength steel with an inverted trapezoid cross section. All walking surfaces are anti-slip.
<b>Outriggers</b>	H-type, out and down outriggers with 5th jack at front bumper. Outrigger control via standard wireless remote control and backup manual valve. Outrigger pads stored under outriggers. Level indicator provided on each side and at rear of crane as well as in the LMI. Span: 21.3 ft×24.3 ft 21.3 ft×21.7 ft 21.3 ft×15.8 ft 21.3 ft×7.6 ft
<b>SUPERSTRUCTURE</b>	
<b>Subframe</b>	Designed and manufactured by XCMG, made of high-strength steel.
<b>Hydraulic System</b>	Variable displacement pumps are used for winching, luffing, and telescoping; a gear pump is used for slewing and outriggers. Separate gear pump used for HVAC. Load-sensing proportional multi-way directional control valve controlled by pilot hydraulic oil. Includes a standard hydraulic oil cooler to control oil temperature in the most demanding applications. Effective volume of oil tank: 158.5 GAL.
<b>Control System</b>	Hydraulic pilot joysticks. Standard LMI display includes crane set up, lift parameters, load charts, lift planning, virtual wall, and fault diagnosis.
<b>Main Winch System</b>	Hydraulic control is used for speed regulation. The system is driven by a hydraulic motor through a planetary gear reducer, with a normally closed brake. Including load hold balance valve and a grooved drum and standard rotation-resistant lift rope.
<b>Operator's Cab</b>	New cab design with more room. Fully-enclosed steel structure with large windows and is tiltable. Safety glass is used for all windows and sun shades are fitted. Wipers are fitted for the windshield and roof window. Standard controls and indicators are ergonomically arranged in the cab. The cab features a new ergonomic seat design with adjustable backrest and armrests that includes joysticks. A sliding door and an electric control pull-out step to facilitate easy and safe access to the cab.
<b>Slewing System</b>	Pilot hydraulic controls a directional valve with built in brake and free swing functions. The system is driven by a piston hydraulic motor through a planetary gear reducer, with a normally closed brake.
<b>Operational Aids</b>	Hydraulic balance valve on outrigger jacks, boom hoist and extension cylinders and winch motors. Hydraulic relief valves on all functions, LMI, 3rd wrap limiter, and anti-two block at boom head.
<b>LMI</b>	The LMI is installed in the control box with its display mounted in the operator's cab. When the load moment approaches overload value, it will send out visual and audible alarms, and automatically stops dangerous movements before overloading. Overload memory function (black box) and fault self-diagnosis functions are built into the system.
<b>Counterweight</b>	Total weight is 16,000 lb, 12,800 lb are self installing/removing.
<b>Hook Block</b>	Hook block 27.5 USt, 5.5 USt

# TECHNICAL SPECIFICATIONS



## BOOM SYSTEM

<b>Boom</b>	5-section, U-shape cross section welded structure. A dual-cylinder and cable telescoping system. The two double-acting cylinders are controlled separately to give 2 mode operation and are fitted with load holding valves. Boom length: 39.4 ~154 ft Boom angle: -5° ~81°.
<b>Auxiliary sheave</b>	Fitted at boom head, used for 8 parts of line and single line operation. Its lifting performance is the same as that for boom, but the maximum lifting load cannot exceed 11,023 lb.

## OPTIONAL EQUIPMENT

<b>Auxiliary Winch System</b>	Hydraulic control is used for speed regulation. The system is driven by a hydraulic motor through a planetary gear reducer, with a normally closed brake. It is equipped with a counterbalance valve, grooved drum and rotation resistant rope.
<b>Control System</b>	Main winch and boom elevation wireless remote control.
<b>Fixed Jib</b>	The jib consists of a connecting bracket, a mechanical link and two lattice sections. Three offset angles of 0°, 15° and 30° are available. Jib length: 30.5 ft and 53.5 ft
<b>Hook Block</b>	Hook block 60 USt, 40 USt, 15 USt.
<b>Boom Tip Camera</b>	Camera on boom head, with screen in operator's cab.
<b>Slewing Lock</b>	360° slewing lock.

Other items of equipment available on request.

BOOM	BOOM + ONE JIB SECTION	BOOM + TWO JIB SECTIONS
T: 39.4 ft~154 ft	T: 154 ft J: 30.5 ft	T: 154 ft J: 53.5 ft



# WORKING RANGE DIAGRAM

## BOOM

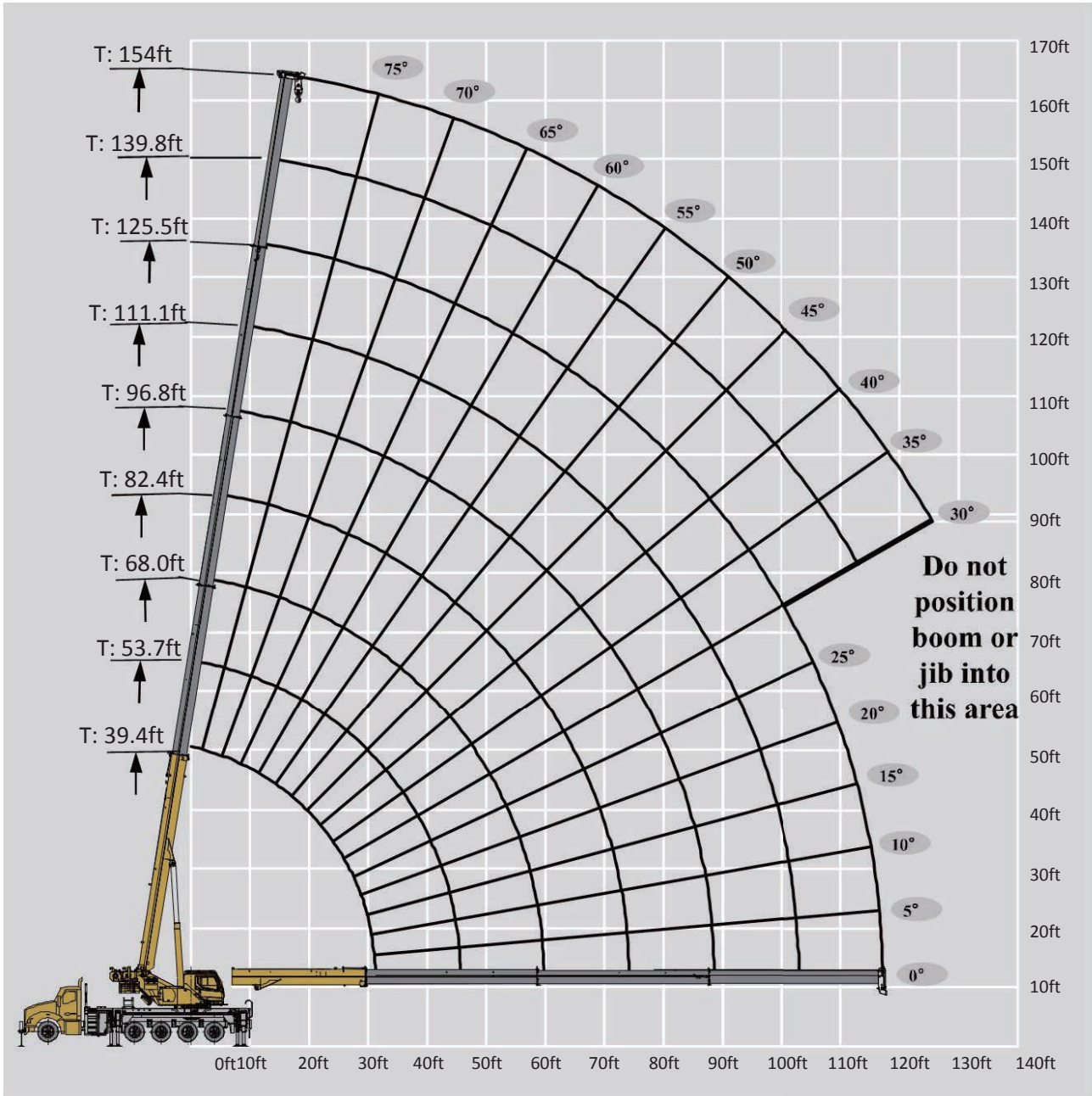





# BOOM TRUCK XCT60\_U

Less Flex, More Lift

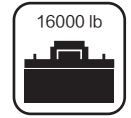
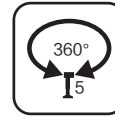
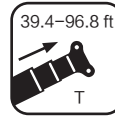
**T 39.4~96.8 ft**

**ASME B30.5 85% Units:lb**



	39.4ft	53.7ft	53.7ft	68ft	68ft	68ft	82.4ft	82.4ft	82.4ft	96.8ft	96.8ft	
5.0	120,000											5.0
6.6	110,220											6.6
8.2	101,410											8.2
9.8	92,590											9.8
11.5	88,180	52,910	70,540									11.5
13.1	77,160	52,910	68,780	50,040	50,700	45,850						13.1
14.8	70,540	52,910	63,710	50,040	50,700	45,850	45,850	42,320	43,870			14.8
16.4	69,220	52,910	58,640	50,040	50,700	45,190	45,850	40,560	41,000			16.4
19.7	59,520	52,910	50,920	46,510	50,700	39,680	43,200	37,250	35,930	39,020	26,450	19.7
23.0	46,510	52,910	45,410	40,780	50,700	34,610	37,910	34,390	31,960	34,830	23,580	23.0
26.2		47,170	40,340	36,370	48,050	30,860	33,730	31,960	28,210	31,960	21,820	26.2
29.5		38,800	35,710	33,280	39,680	27,990	30,860	30,200	25,350	29,100	20,060	29.5
32.8		32,620	29,760	30,420	33,500	25,130	27,990	28,430	22,920	26,230	18,730	32.8
39.4				22,920	25,130	20,720	23,580	24,470	18,950	22,260	16,310	39.4
45.9				17,630	19,620	15,430	18,510	20,060	15,870	18,730	14,550	45.9
52.5							14,770	16,310	13,000	15,210	12,560	52.5
59.1							11,900	13,440	10,140	12,340	11,240	59.1
65.6										10,140	10,140	65.6
72.2										8,370	9,470	72.2
Boom angle 0°	23,140	13,440	11,680	7,490	8,810	6,170	5,290	6,170	3,960	3,740	4,620	
	0	0%	50%	50%	0	100%	50%	0	100%	50%	0	
	0	16.70%	0%	16.70%	33.30%	0	33.30%	50%	16.70%	50%	66.70%	
	0	16.70%	0%	16.70%	33.30%	0	33.30%	50%	16.70%	50%	66.70%	
	0	16.70%	0%	16.70%	33.30%	0	33.30%	50%	16.70%	50%	66.70%	

# LOAD CHARTS

**T 96.8~154 ft**

**ASME B30.5 85% Units:lb**

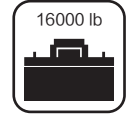
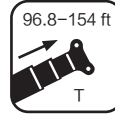

	96.8ft	111.1ft	111.1ft	111.1ft	125.5ft	125.5ft	125.5ft	139.8ft	139.8ft	154ft	
19.7	32,840										19.7
23.0	28,880										23.0
26.2	26,010	22,700	18,950	23,360							26.2
29.5	23,800	21,380	17,630	21,600	17,850	15,650	18,510				29.5
32.8	22,040	20,280	16,530	19,840	16,970	14,320	17,190	14,320	14,770	11,460	32.8
39.4	18,070	17,850	14,320	16,970	15,210	13,000	14,770	13,000	13,000	11,020	39.4
45.9	15,210	15,650	12,780	14,100	13,440	11,240	13,220	11,680	11,680	9,920	45.9
52.5	13,000	14,100	11,240	12,120	12,340	10,140	11,900	10,580	10,360	9,030	52.5
59.1	11,020	12,780	9,920	10,800	10,580	9,030	10,140	9,470	9,250	8,150	59.1
65.6	8,810	10,580	8,810	9,250	9,700	8,150	8,810	8,150	7,930	7,270	65.6
72.2	7,050	8,810	8,150	7,710	8,590	7,490	7,490	7,490	7,270	6,390	72.2
78.7		7,270	7,270	6,170	7,710	6,830	6,610	6,830	6,390	5,730	78.7
85.3		6,170	6,610	5,070	6,390	6,170	5,510	6,170	5,730	4,850	85.3
91.9					5,510	5,510	4,400	5,510	4,620	4,620	91.9
98.4					4,620	5,290	3,520	4,850	3,740	3,960	98.4
105.0								3,960	3,080	3,300	105.0
111.5								3,300	2,420	2,640	111.5
118.1								2,640	1,760	1,980	118.1
124.7										1,540	124.7
131.2										1,100	131.2
Boom angle 0°	2,640	2,640	3,300	1,760	1,760	2,200	1,100				
	100%	50%	0	100%	50%	0	100%	50%	100%	100%	
	33.30%	66.70%	83.30%	50%	83.30%	100%	66.70%	100%	83.30%	100%	
	33.30%	66.70%	83.30%	50%	83.30%	100%	66.70%	100%	83.30%	100%	

# BOOM

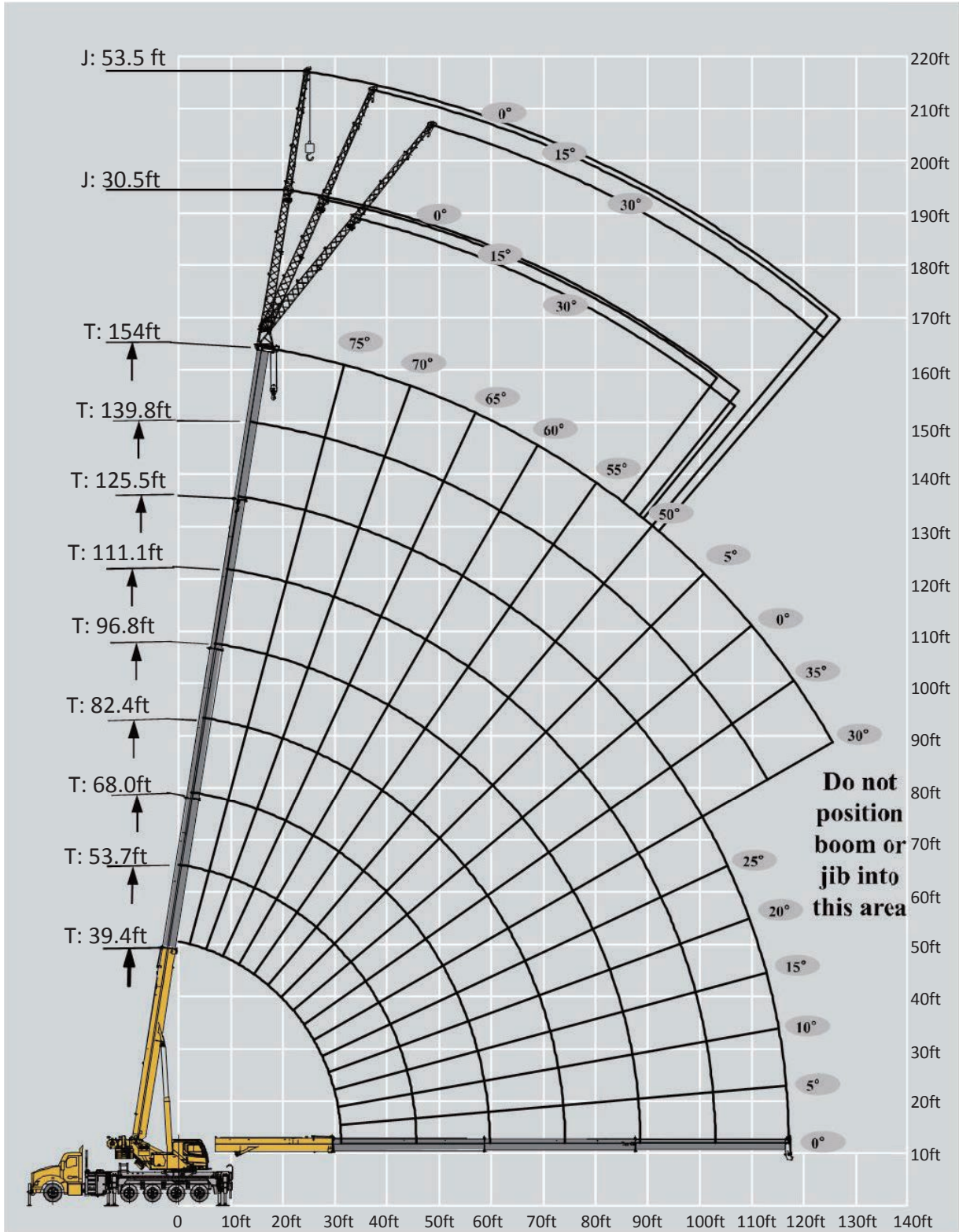



**T 154 ft**

**ASME B30.5 85%**

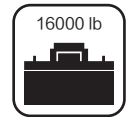
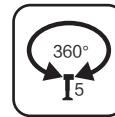
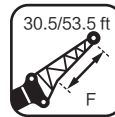
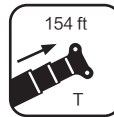
**Units:lb**



	154 ft			154 ft			
	30.5 ft			53.5 ft			
	0°	15°	30°	0°	15°	30°	
45.9	7,050			5,290			45.9
52.5	7,050	7,050		5,290			52.5
59.1	7,050	6,390	4,400	5,070	3,300		59.1
65.6	5,730	5,510	4,180	4,620	3,080		65.6
72.2	4,850	4,850	3,960	4,400	3,080	1,980	72.2
78.7	4,400	4,400	3,960	3,960	2,640	1,980	78.7
85.3	3,960	3,740	3,740	3,740	2,640	1,760	85.3
91.9	3,300	3,300	3,520	3,080	2,420	1,540	91.9
98.4	2,860	2,860	2,860	2,640	2,640	1,540	98.4
105.0	2,420	2,420	2,420	2,200	2,420	1,540	105.0
111.5	2,200	2,200	1,980	1,980	2,200	1,320	111.5
118.1	1,760	1,760	1,760	1,760	1,760		118.1
124.7				1,540	1,540		124.7
131.2					1,540		131.2
137.8					1,100		137.8

# WORKING AREAS

For full 360° rotation, the fifth jack must be set per the operator's manual and the machine must be level. Without the fifth jack properly set, the crane can only be operated with the boom over side or over rear.

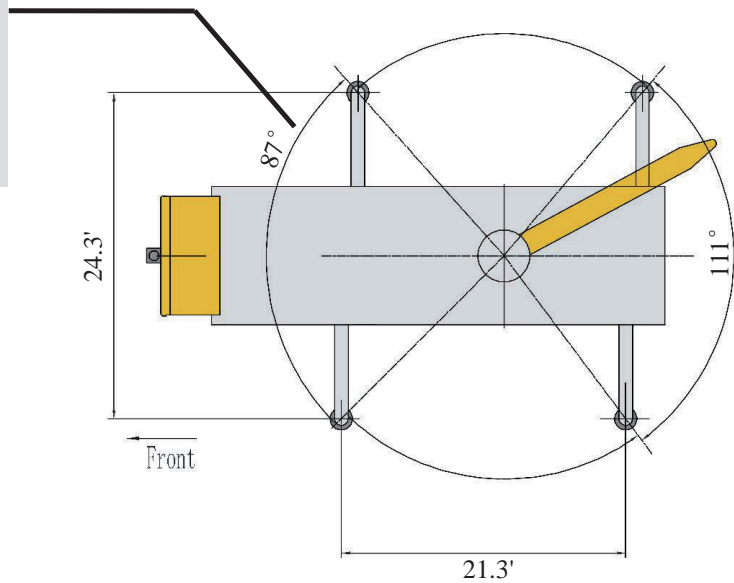



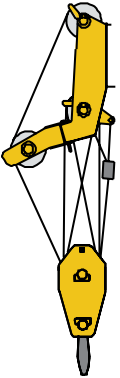
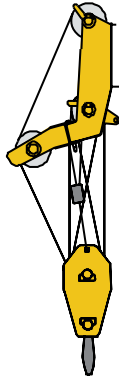
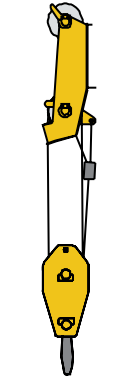
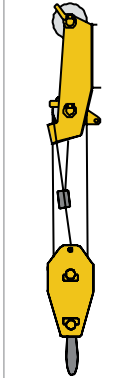
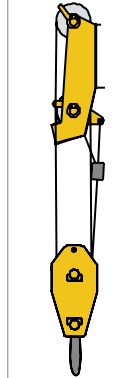
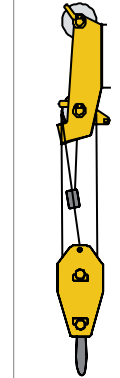
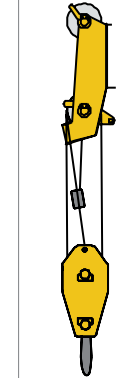
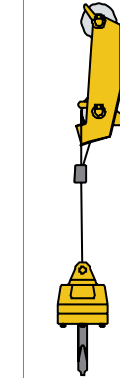







# REEVING DIAGRAM



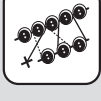









ALLOWABLE LINE PULL								WARNING
8 parts of line	7 parts of line	6 parts of line	5 parts of line	4 parts of line	3 parts of line	2 parts of line	1 part of line	Refer to the owners manual  Incorrect reeving or incorrect input of parts of line may result in serious accidents.  Keep at least three turns of rope left on the drum at all times
								
82,252 lb	72,683 lb	62,913 lb	52,954 lb	42,787 lb	32,412 lb	21,826 lb	11,023 lb	Min. breaking strength 56,217 lb

CATEGORY	ITEM		UNIT	PARAMETER
Dimensions	Overall length		in	548.8
	Overall width		in	102
	Overall height		in	153.5
	Axle spacing		in	176+54+54+54
Weights	Maximum permissible total weight (equipped with 27.5 USt hook block, 5.5 USt hook (other hook blocks not included), jib, and 3200 lb fixed counterweight (other counterweight slabs not included); auxiliary winch not included)		lb	79,366
	Axle load	Axle 1	lb	16,511
		Axle 2	lb	13,220
		Axles 3-5 (in tandem)	lb	49,635
Power	Engine model		—	MX-13
	Rated power/rpm		HP/rpm	455/1600
	Maximum output torque/rpm		lb-ft/rpm	1650/900
Travel	Maximum travel speed		mph	65
	Minimum turning diameter		in	945
	Minimum turning diameter of boom head		in	1,024
	Minimum ground clearance		in	13.8
	Approach angle		°	16
	Departure angle		°	13

# TABLE OF MAIN TECHNICAL PARAMETERS

CATEGORY	ITEM		UNIT	PARAMETER	
Main Performance	Maximum rated lifting capacity		USt	60	
	Minimum rated working radius		ft	5	
	Slewing radius at turntable tail (at counterweight)		ft	13.8	
	Maximum load moment	Base boom section	lb-ft	1,172,000	
		Fully-extended boom	lb-ft	481,000	
		Fully-extended boom + Jib	lb-ft	416,000	
	Outrigger span (fully-extended)	Longitudinal	ft	21.3	
		Lateral	ft	24.3	
	Lifting height	Base boom section	ft	42.6	
		Fully-extended boom	ft	154	
		Fully-extended boom + Jib	ft	208	
	Boom length	Base boom	ft	39.4	
Fully-extended boom		ft	154		
Fully-extended boom + Jib		ft	207.5		
Jib offset angle		°	0, 15, 30		
Working Speeds	Time for raising boom		s	40	
	Time for fully extending boom		s	80	
	Maximum slewing speed		rpm	1.2	
	Time for extending and retracting outriggers	Outrigger beams	Extending	s	≤40
			Retracting	s	≤40
		Outrigger jacks	Extending	s	≤45
			Retracting	s	≤45
Lifting speed (single line, 4th layer, no load)	Main winch system	fpm	394		

	Superstructure
	Rated Lifting Load
	Counterweight
	Slewing Radius of Variable-position Counterweight
	Hook Block
	Parts of Line
	Boom Length Combination
	Wind Speed
	Configuration
	Optional Equipment
	Wire Rope Length
	Wire Rope Diameter

	Boom
	Boom Length
	Working Radius
	Lifting Height with Boom
	Boom Angle
	Extension
	Independent Jib Head
	Simple Jib Head
	Fixed Jib
	Fixed Jib Length
	Fixed Jib Offset Angle
	Luffing Jib

# DESCRIPTION OF SYMBOLS

	Maximum Single Line Pull		Maximum Lifting Height
	Maximum Working Speed		Maximum Working Radius
	Main Winch		Super Lift
	Auxiliary Winch		Wind Power Jib
	Chassis		Telescoping
	Outrigger Span		Slewing
	Tires		360° Slewing
	Axle Load		360° Slewing with the 5th Jack Down
	Gradeability		Side and Rear Operation
	Travel Speed		Operation Over Front
	Luffing		Operation Over Rear
	EN 13000 Standard		Luffing Jib Winch

## TESTED AT EVERY LEVEL

- Each new technology and component is required to meet the most stringent design and quality protocols.
- Each complete machine undergoes rigorous run in and testing, components are subject to ongoing testing.

## OVER 2,000 COMPONENTS FROM 123 MANUFACTURERS UNDERGOING LIFE CYCLE TESTING



HMI Display: Low-Temperature Performance Test Under -40°C

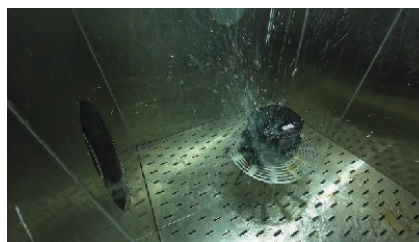

Length Measurement Sensor: 48-Hour Rain Test



Panel Buttons: Cycled 12 Million Times



Hydraulic Pump: Low-Temperature Performance Test Under -40°C

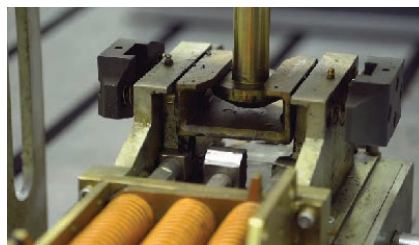

Telescoping Mechanism: Smoothness Test

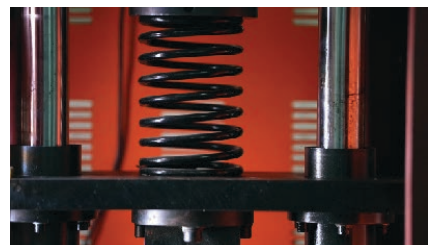

Telescoping Mechanism: Smoothness Test

## 178 POST PRODUCTION FULL-SCALE TESTS ON THE COMPLETE MACHINE



Dynamic & Static Lifting



Terrain Testing



Climbing & Hill Holding

# NOTES FOR LIFTING

- ❖ The total rated loads given in the rated load charts are the maximum lifting capacity when the crane is set up on firm and level ground with the tires free of the ground. The weights of the hookblock, rigging and the rope between the boom tip and block must be deducted as well as optional items such as the auxiliary sheave and jib.
- ❖ The working radius shown in the rated load charts is the radius when the load is lifted off the ground, and it is the actual value including loaded boom deflection. The operator will need to take boom deflection into consideration before beginning a lifting operation.
- ❖ A lifting operation is permissible only when the wind force is below grade 5 (instantaneous wind speed is 14m/s (46.2ft/s), and wind pressure is below 124Pa (2.59lb/ft<sup>2</sup>).
- ❖ Before beginning lifting operation, the operator should know the weight of the load to be lifted and the crane's working range, and then select proper working conditions. Never operate the crane beyond the limit shown in the chart. Use the lower value from the chart when the boom length or working radius is between the range of values.
- ❖ Observe the boom angle limit. Never operate the crane with the boom angle beyond the recommended limit even if a load is not being carried. Otherwise, the crane may overturn.
- ❖ The boom should be extended according to the telescoping codes shown on the load charts.



**Address: 305A Equipment Ct NE**

**Lawrenceville, GA 30046**

**Email: [cranes@xcmgusa.com](mailto:cranes@xcmgusa.com)**

**Website: [xcmg-usa.com/products/cranes-and-hoisting](http://xcmg-usa.com/products/cranes-and-hoisting)**

## **Do not copy without authorization!**

This document is non-contractual. Constant improvement and engineering progress make it necessary that we reserve the right to make product model, specification and configuration changes without notice. Illustrations shown may include optional equipment and accessories and may not include all standard equipment. Some parts need to be purchased separately. Conform to the local laws for license application and road traveling.



**American  
Crane  
Products**



**XCMG  
North America**