



# ROUGH TERRAIN CRANE

# XCR130\_U

Reach That Matters

 117 t  
(129 USt)

 50 m  
(164 ft)

 56 m  
(183.7 ft)

 64.8 m  
(212.5 ft)





# CONTENTS

Product Advantages and Highlights	1-9
Dimensions	10
Technical Specifications	11-12
Optional Equipment/ Weights	13
Working Speeds	14
Counterweight	15
Boom / Jib Combinations	16
Load Charts (Metric)	17-23
Load Charts (Imperial)	24-29
Table of Main Technical Parameters	30-31
Description of Symbols	32-33



## BUILT AROUND THE OPERATOR.



## BEST SEAT IN THE HOUSE

### 3.6 FT EXTRA-LARGE CAB. BUILT FOR ANY OPERATOR, ANY SHIFT.

Dust-sealed and noise-reducing. The generously sized seat with extra head, shoulder, and arm room means any size operator feels right at home.

①	Large Windshield	Large windshield and top glass reduce blind spots for improved safety during lifting and driving. Includes top and front sunshades.	⑧	Engine Start/Stop	Separate engine stop switch independent of the ignition switch. Gives the operator the ability to start and stop the engine and leave the LMI active.
②	Engine Information	Always displaying relevant engine information including RPM, temperature, fuel level, and oil pressure.	⑨	Steering Comfort	Steering column both telescopes and tilts.
③	HVAC	Adjustable air outlets on dash, behind the operator, at floor level, and defroster vents for maximum comfort.	⑩	All Day Power	Stay powered with 12 and 24V power ports, as well as USB radio input and Bluetooth.
④	Emergency Stop Switch	Easy to reach from the seat and outside with the door open, just in case.	⑪	Stay Hydrated	Cupholders and storage bins throughout.
⑤	Operation Display	10.4-inch true-color touchscreen with adjustable angle. Easy to read, easy to navigate, with operational and diagnostic information at a glance.	⑫	Seat	Adjustable cushion height, back rest angle, headrest, fore-aft, and armrests.
⑥	Camera Display	Split-screen display monitors the winches and behind when reversing, as well as boom tip cameras.	⑬	Outrigger Controls	Select which beams or jacks to move then hit extend or retract. No contorting to press multiple buttons.
⑦	Control Lever	Joysticks include winch rotation tactile feedback as well as operator presence, horn, free swing, and high speed mode buttons.	⑭	Adjustable Joystick Pods	Joystick pods are independently adjustable from the seat for maximum comfort.

**FGETS IN. GETS OUT. GETS THE JOB DONE.**

- Four steering modes including crab, tight-turn, independent front axle, and independent rear axle. All controlled from the steering wheel, the way it should feel.
- 6 forward and 2 reverse gears with a 27.6 ft minimum turning radius. Gets in and out of tight spaces as well as covers long distances with ease.

**BUILT FOR THE WORST GROUND ON THE JOBSITE.**

- 310 hp Tier 4 Final engine paired with a low-speed, high-torque hydraulic torque converter drivetrain. All-axle drive with deeply lugged radial tires handle potholes, muddy roads, and rough terrain without slowing down.



## WHERE IT COUNTS: THE BOOM.

### 164 FT. FIVE SECTIONS. TWO TELESCOPING MODES.

- 164 ft five-section boom with two telescoping modes. When the jib is installed, maximum tip height reaches 224 ft. Whatever gets put in front of you, this boom gets there.
- Independent telescoping of section 2 and synchronous telescoping of sections 3 through 5 give the operator precise control over boom configuration for any lift.



## DUAL VARIABLE PUMP CONTROL SYSTEM

- Dedicated dual-variable displacement pumps for fully independent winch and boom control, with the ability to combine flow for high-speed operation.
- Separate pump for outriggers and slewing, and an independent pump for the AC system.
- Automatic temperature-controlled hydraulic oil cooler maintains performance in high and low temperature environments

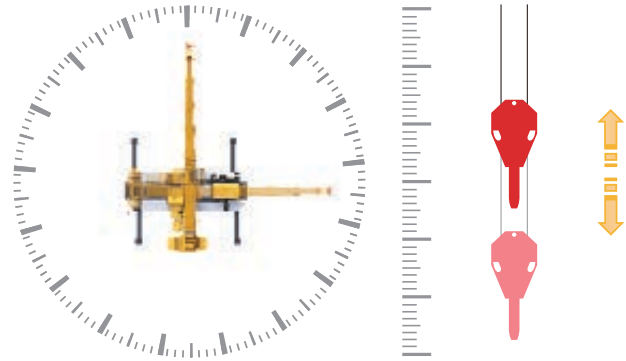

## FINE CONTROL

Millimeter precision when winching, slewing, and luffing.



## AUTO WINCH AND BOOM COMPENSATION CONTROL SYSTEM

- **Hook Height Compensation**  
The control system automatically manages winch rope spooling during telescoping and luffing operations, reducing setup time and keeping the hook at the right height throughout the lift..

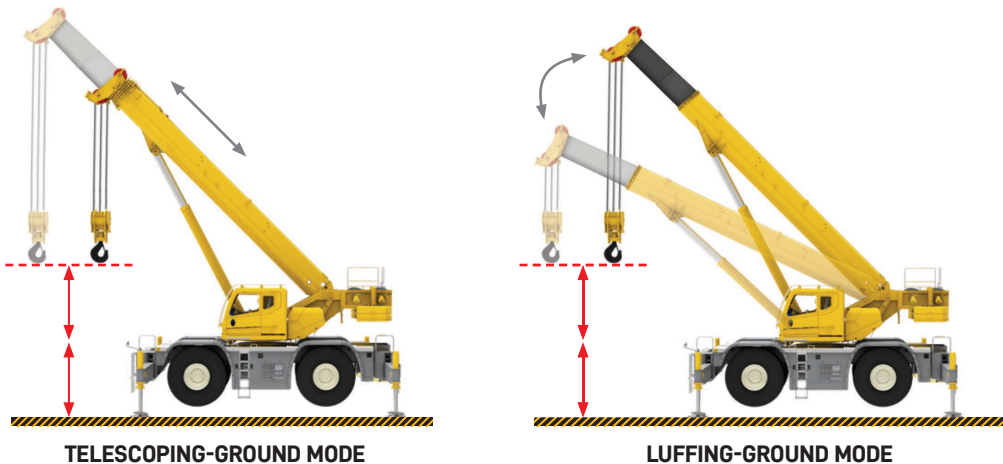

# ONE KNOB. ONE STEP. DONE.

## AUTOMATIC STEERING MODE SWITCHING WITH REAR WHEEL AUTO-CENTERING

- Switch steering modes with the turn of a knob. The XCR130U automatically centers the rear wheels, no manual alignment needed.
- A dedicated display shows exact wheel position and system status in real time.

## XCMG: TURN THE KNOB. THE CRANE HANDLES THE REST

### XCMG MULTI-MODE STEERING TECHNOLOGY WITH REAR WHEEL AUTO CENTERING

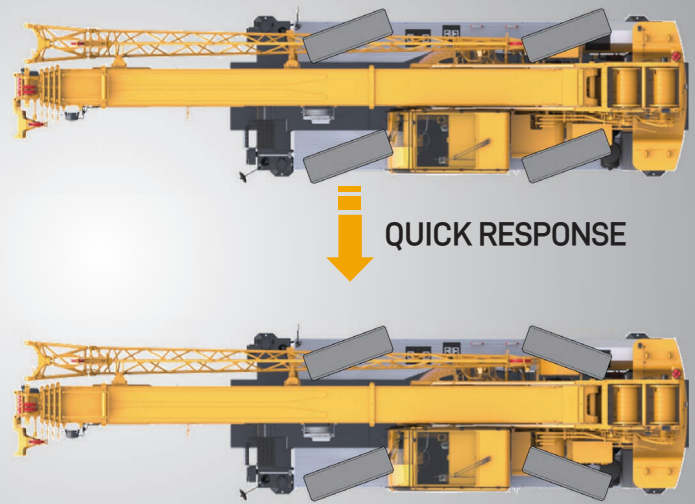

## HOW OTHER BRANDS SWITCH STEERING MODES

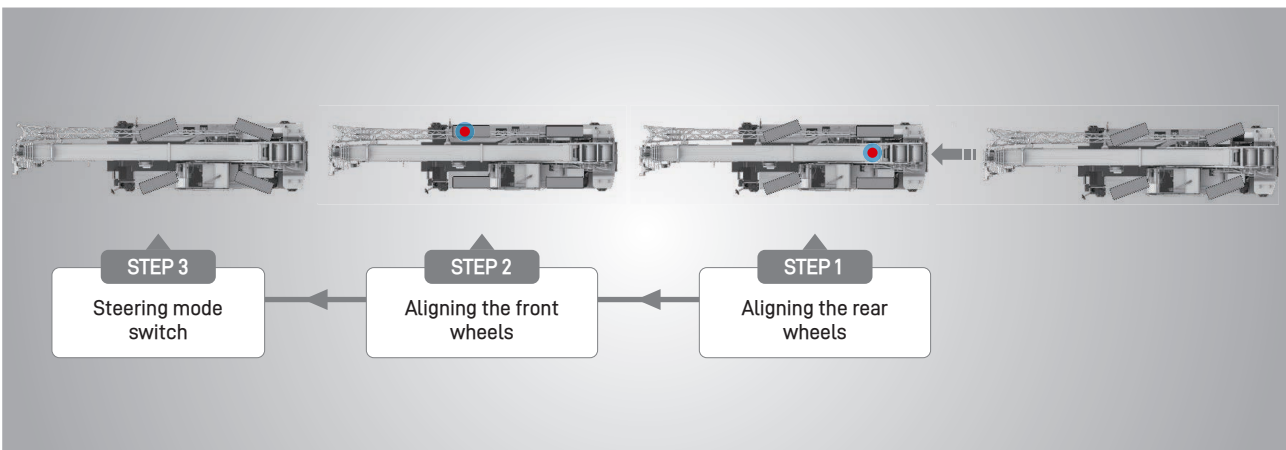

**LOWER FUEL COSTS. FULL LIFTING POWER.**

- Valve-controlled load sensing paired with dual-variable pumps means the hydraulic system only uses the power the lift actually needs. Gravity-assisted luffing on boom-down lets physics do the work instead of fuel. The result: 10–15% lower fuel consumption across all operating modes. Low-pressure-loss valves and piping throughout minimize wasted energy.



# SUPERIOR PERFORMANCE LEADING THE INDUSTRY IN

## ECO MODE

- ECO mode limits engine speed and relies on high-flow pumps to maintain full lifting performance at lower RPM. The engine stays in its most efficient operating range, delivering the lowest fuel consumption in the class during lifting operations.

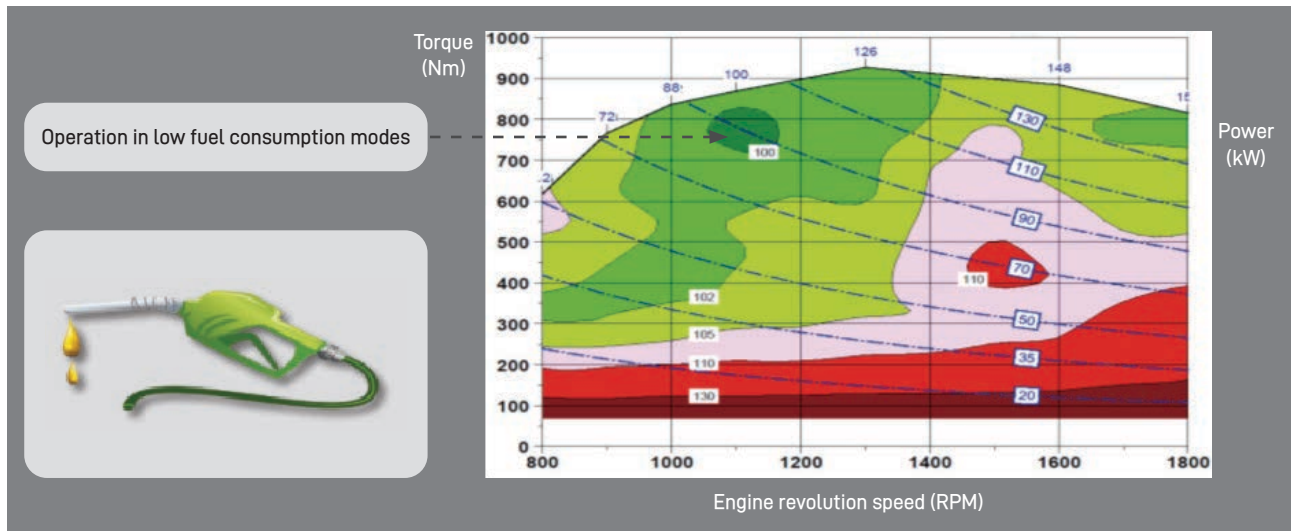

## EFFICIENT HYDRAULIC TORQUE CONVERTER DRIVETRAIN

- The lock-up torque converter delivers efficient high-speed travel and multiplies torque at low speeds when the terrain demands it.
- At creep speeds, hydraulic torque multiplication pulls the crane through the toughest ground conditions.
- At higher travel speeds, the converter bypasses to a direct mechanical drive connection between the engine and transmission for maximum efficiency.

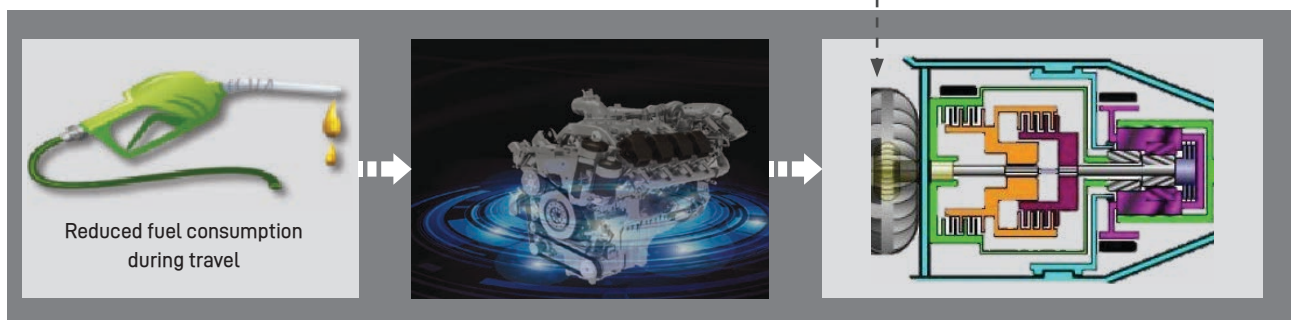
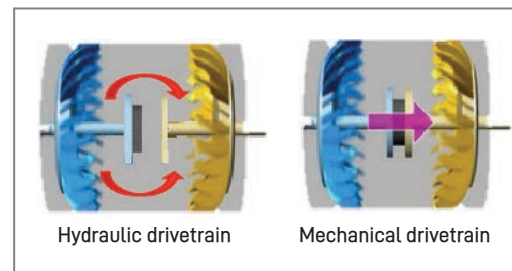

**BUILT AROUND THE OPERATOR**

- With complete cab and deck, and maintenance access, the operator can get on the vehicle from all four sides no matter the upper rotation.
- Professional ergonomic simulation analysis, and user-friendly detailed design.

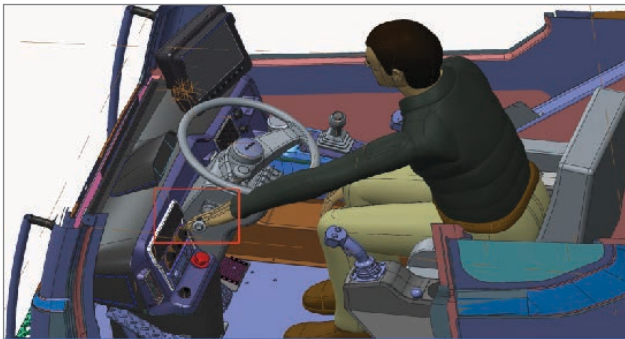
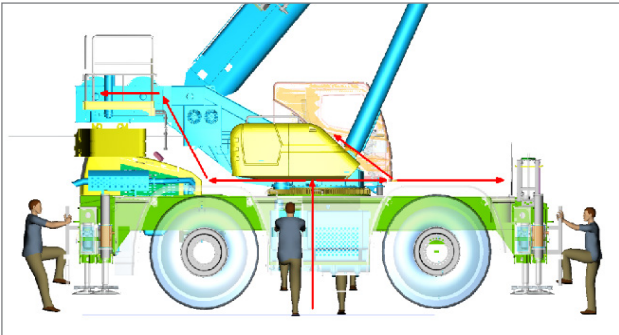

The pressure testing ports are centrally arranged.



Main power switch

## THE DETAILS THAT MAKE THE DIFFERENCE.

### SEE EVERYTHING. MISS NOTHING.

- Winch monitoring camera keeps eyes on the load during every lift, from hook-up to set-down.
- Backup camera activates automatically when traveling in reverse.
- Optional zoomable boom tip camera for a closer view of the lifted load.

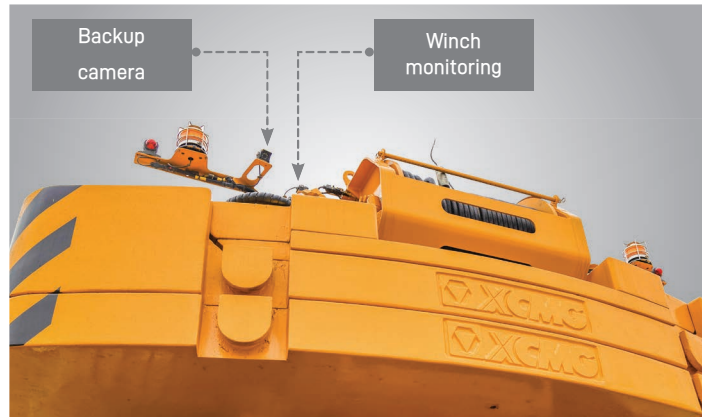

### CLIMATE CONTROLLED. EVERY CORNER OF THE CAB.

- High-power HVAC with multi-directional air vents delivers uniform airflow throughout the cab.
- Vents at foot level, dash level, and directed at the windshield for defrost.
- Diesel fuel-fired heater for near-instant heat.



### WIRED TO WITHSTAND THE JOBSITE.

- All sealed electrical connectors throughout.
- Centralized electrical panels with all controllers, fuses, and relays in one location.
- Intelligent wire routing and clamping to maximize crane uptime.





# TECHNICAL SPECIFICATIONS



## CONFIGURATION

Frame	High-strength fine-grained steel. Welded torsion-resistant box-section construction. High load-bearing capacity.
Outriggers	4 outriggers in H configuration, mounted on both sides of the frame. Electro-hydraulic control from the cab with electronic level. Outrigger float dimensions: 1.8 × 1.8 ft (550 × 550 mm).
Engine	L9 inline six-cylinder, water-cooled diesel. U.S. EPA Tier 4 Final compliant. Power: 310 hp / 2,100 rpm (231 kW). Torque: 1,126 lb-ft / 1,400 rpm (1,526 N·m). Fuel tank capacity: approximately 81 gal (305 L). DEF tank capacity: 8 gal (30 L).
Transmission	ZF 6WG260 automated powershift transmission. 6 forward, 3 reverse gears. Drop box configuration with emergency steering pump and interaxle lock-up.
Axles	Heavy duty drive/steering axles with disk brakes and deferential locks.
Suspension	Front axle: rigidly mounted to the frame. The rear axle is mounted with a center pivot that locks solid during pick and carry operation.
Tires	875/65R29 tires designed for rough terrain cranes.
Brake	Service brake: dual-circuit hydraulic disc brakes on all wheels. Automatic braking and low-pressure alarm activate if system pressure drops. Parking brake: spring-loaded brake acting on front and rear axles.
Steering	Four steering modes: independent front axle, independent rear axle, tight-turn, and crab. Rear axle auto-centers when switching modes.
Hydraulic system	Dual-variable displacement pump for lifting, luffing, and telescoping. Gear pump for slewing, outrigger, steering, and braking operations. Load-sharing proportional multi-way control valve. Independent hydraulic oil cooler. Tank capacity: approximately 323.6 gal (1,225 L).
Electrical system	24V DC. Two 180 Ah 12V batteries in series. LMI and crane control via CAN bus system. Standard lighting includes headlights, brake lights, turn signals, backup lights, work lights on turntable, boom, and cab.

**CONFIGURATION**

<b>Boom</b>	1 base boom section and 4 telescoping sections. U-shape cross-section. Dual-cylinder wire-rope telescoping system. 6 sheaves on boom head standard. Boom length: 42.3–164.0 ft (12.9–50 m).
<b>Jib</b>	Two-section lattice structure with offset angles of 0°, 15°, and 30°. Stowed along the side of the boom. Jib length: 35.4–60.0 ft (10.8–18.3 m).
<b>Control System</b>	Electrically controlled pilot system with dual-axis levers for all primary crane movements.
<b>Main Winch</b>	Grooved drum driven by a hydraulic motor through a planetary gear reducer. Normally closed brake with counterbalance valve.
<b>Slewing System</b>	Single-row four-point ball contact slewing ring. Hydraulic motor drive with planetary gear reducer. Spring-applied, hydraulic-release brake. Free swing mode included..
<b>Cab</b>	Tiltable to 20° with sliding door. Large safety glass windows and roof guardrail. Top and front sliding sunscreens standard. Multi-way adjustable seat with armrests. Heater, air conditioner, radio, and 12V/24V power ports included..
<b>Optional Aids</b>	Hydraulic counterbalance valves and relief valves. Full-featured LMI system with anti-two-block and winch overwind protection.
<b>Counterweight</b>	Standard self-removing: 35,274 lb (16 t).
<b>Hook Block</b>	66 USt (60 t) and 7.7 USt (7 t) hook blocks.
<b>Luffing System</b>	Single-cylinder luffing with counterbalance valve and load compensation.
<b>Auxiliary Sheave</b>	Stowable on boom tip for single part of line.
<b>360° Slewing Locking Device</b>	House lock engages the slew gear teeth to lock the upper in any position.

Product parts list is as mentioned above. Please refer to the product quotation for specific parts.

## OPTIONAL EQUIPMENT/WEIGHT



OPTIONAL EQUIPMENT	COMPONENT DESCRIPTION
Hook Block	121 USt (110 t) hook block
Counterweight	Total weight 15,432 lb (7 t), consisting of two 6,393 lb (2.9 t) pieces and one 2,646 lb (1.2 t) piece
Auxiliary Winch	Hydraulic motor drive through a planetary gear reducer. Normally closed brake with counterbalance valve.



CONFIGURATION	WEIGHTS	FRONT AXLE	REAR AXLE
Basic configuration	111,384 lb (50,523 kg)	82,326 lb (37,342.5 kg)	29,058 lb (13,180.5 kg)
Add: 35,274 lb (16 t) counterweight	35,274 lb (16,000 kg)	-12,297 lb (-5,578.1 kg)	47,572 lb (21,578.1 kg)
Add: 15,432 lb (7 t) counterweight	15,432 lb (7,000 kg)	-5,308 lb (-2,407.9 kg)	9,408.9 kg (20,743.1 lb)
Add: Auxiliary winch system with wire rope	1218 kg (2,685.2 lb)	-542.7 kg (-1,196.4 lb)	3,882 lb (1,760.7 kg)
Add: Jib	3,263 lb (1,480 kg)	5,375 lb (2,438.1 kg)	-2,112 lb (-958.1 kg)
Add: Auxiliary sheave	157 lb (71 kg)	436 lb (198 kg)	-279 lb (-126.9 kg)
Add: 121 USt (110 t) hook block (stowed at front)	2,244 lb (1,018 kg)	4,372 lb (1,982.9 kg)	-2,127 lb (-964.9 kg)
Add: 66 USt (60 t) hook block (stowed at front)	1,102 lb (500 kg)	2,147 lb (973.9 kg)	-1,045 lb (-473.9 kg)
Add: 66 USt (60 t) hook block (stowed at front)	567 lb (257 kg)	567 lb (257 kg)	-171 lb (-77.6 kg)





Note: If the 50,706 lb (23 t) total counterweight is installed, short-distance transfer only. Travel speed must not exceed 3.1 mph (5 km/h).









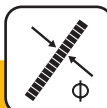

HOOK BLOCK	SHEAVE NUMBER	PARTS OF LINE	WEIGHT lb (kg)	DIMENSIONS	NOTES
121 USt (110 t)	6	13	2,245 (1,018)	2.1 × 1.9 × 5.74 ft (640 × 580 × 1,749 mm)	Dual-hook
66 USt (60 t)	3	6	1,102 (500)	1.48 × 1.94 × 4.9 ft (450 × 590 × 1,494 mm)	Single-hook
7.7 USt (7 t)	1	1	1,102 (500)	2.4 × 1.4 ft diameter (731 × 426 mm)	Single-hook

ROUGH TERRAIN CRANE **XCR130\_U**

Reach That Matters

			
875 / 65R29		18.6 mph (30 km/h)	80%

				
	0-442.8 ft/min (0-135 m/min), single line, no load	22,256 lb (99 kN)	0.866 in (22 mm)	820 ft (250 m)
	0-295.2 ft/min (0-90 m/min), single line, no load	15,961 lb (71 kN)	0.866 in (22 mm)	492 ft (150 m)
	0-1.8 rpm			
	Approx. 55 s for boom luffing up from 0° to 80°			
	Approximately 125 sec, 43.2 ft to 164.0 ft (12.9 m to 50 m)			

# COUNTERWEIGHT

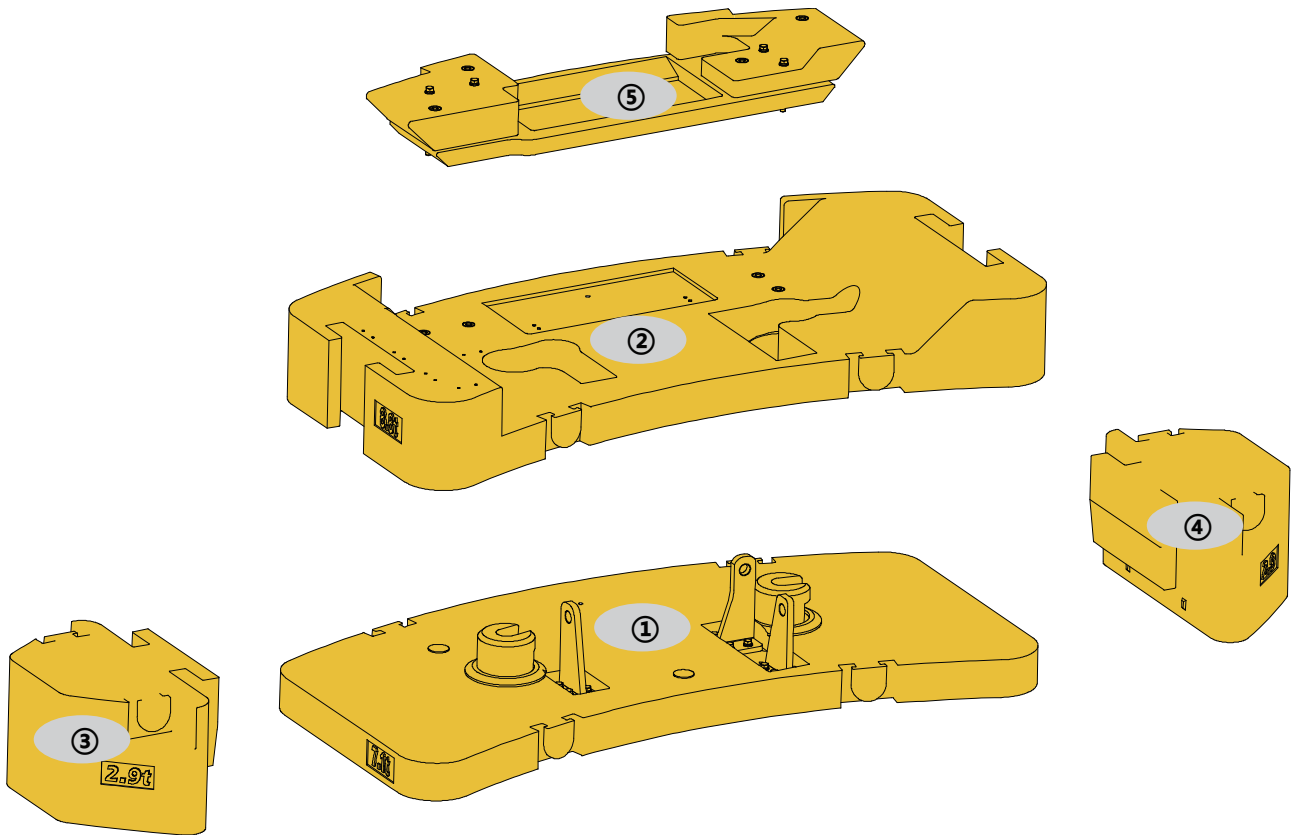

	①	②	③	④	⑤
<b>Dimensions (L×W×H) ft (mm)</b>	11.4 × 6.3 × 1.9 ft (3,480 × 1,850 × 570 mm)	11.4 × 6.3 × 1.5 ft (3,480 × 1,850 × 455 mm)	4.1 × 2.6 × 2.1 ft (1,241 × 787 × 655 mm)	4.1 × 2.6 × 2.1 ft (1,241 × 787 × 655 mm)	8.1 × 2.4 × 0.8 ft (2,475 × 720 × 256 mm)
<b>Weight lb (t)</b>	15,874 (7.2)	19,400 (8.8)	6,393 (2.9)	6,393 (2.9)	2,646 (1.2)

<b>OPERATION MODE</b>	<b>50,706 lb (23 t)</b>	<b>35,274 lb (16 t)</b>	<b>0 T (0 LB)</b>
<b>Combinations</b>	① + ② + ③ + ④ + ⑤	① + ②	—

BOOM	BOOM+ 1ST FIXED JIB	BOOM+ 2ND FIXED JIB
42.3-164.0 ft (12.9-50 m)	T: 164 ft (50 m) F: 35.4 ft (10.8 m)	T: 164 ft (50 m) F: 60.0 ft (18.3 m)



# WORKING RANGE DIAGRAM

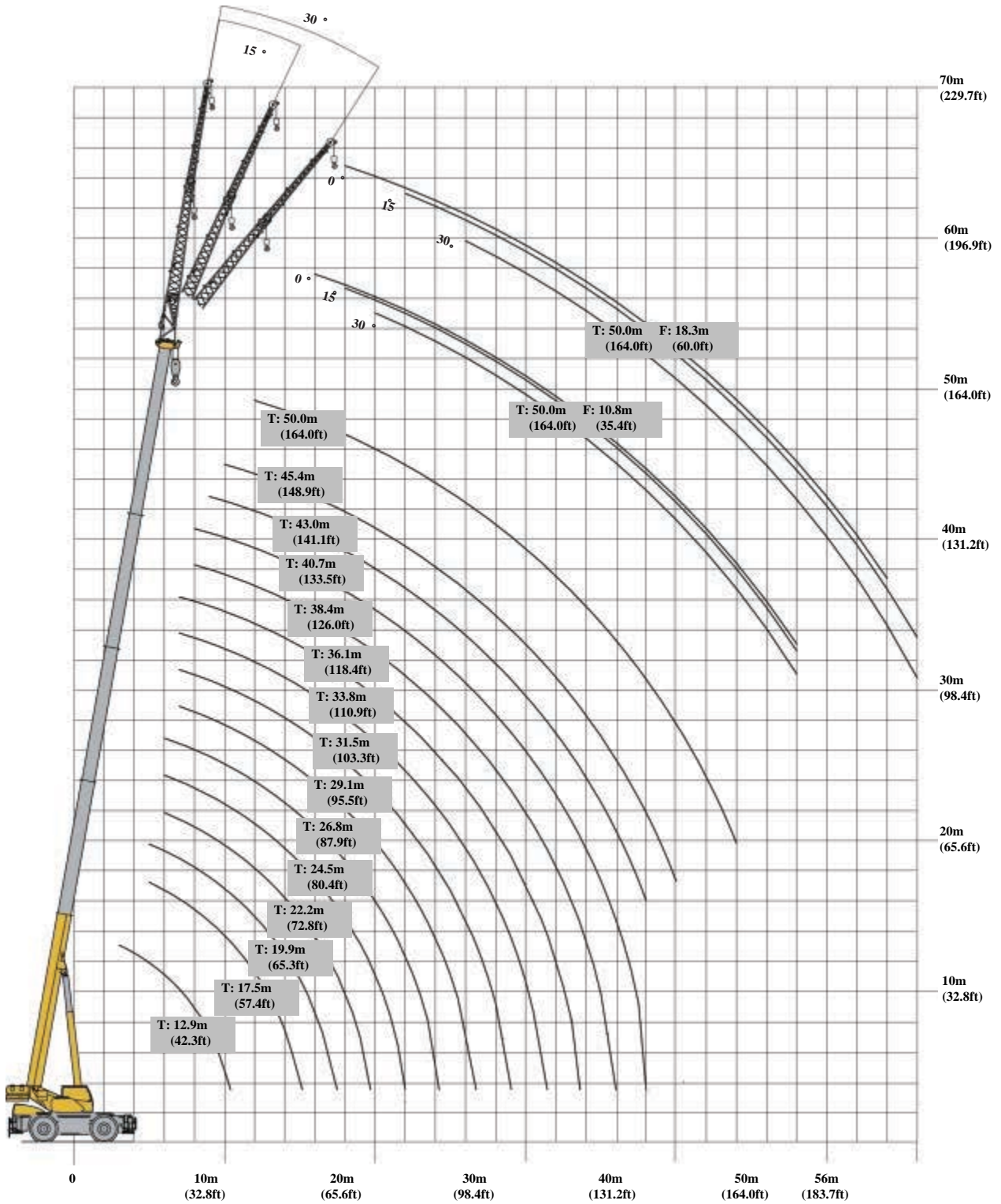

**BOOM**  
ASME B30.5 85%

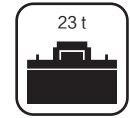
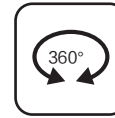
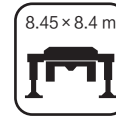

	12.9	17.5	19.9	22.2	24.5	26.8	29.1	31.5	33.8	36.1	38.4	40.7	43.0	45.4	50.0	
2.5	117*															2.5
3	110.0															3
4	90.0															4
5	72.0	70.0	39.2													5
6	60.0	59.5	40.3	56.0	37.5	39.2										6
7	52.0	52.0	41.3	52.0	38.6	40.0	37.0	30.1	28.0	31.0						7
8	45.5	45.5	42.3	45.0	39.1	37.5	37.0	30.5	26.3	30.5	22.5	20.6				8
9	39.0	40.3	40.0	39.6	40.1	35.2	35.0	28.0	24.7	27.5	21.6	19.8	19.5			9
10	28.5	35.1	34.8	34.5	35.5	33.1	31.0	26.5	23.4	27.6	20.4	18.7	18.9	17.4		10
12		25.3	27.5	25.6	28.3	28.7	27.0	22.4	21.2	24.4	18.5	17.2	17.3	17.0	13.9	12
14		19.1	21.2	19.0	21.2	22.1	20.2	21.3	19.2	21.1	16.6	15.2	15.7	15.9	13.4	14
16			16.5	14.5	16.6	17.5	15.6	17.1	17.5	16.5	15.5	13.5	14.0	14.1	12.4	16
18				11.3	13.3	14.4	12.4	13.8	15.0	13.3	14.4	12.2	12.6	12.7	12.0	18
20					10.8	12.1	10.0	11.4	12.5	10.9	11.9	11.1	11.4	11.5	10.8	20
22					6.9	10.4	8.2	9.5	10.6	9.0	10.0	10.0	9.5	10.3	9.5	22
24						6.8	6.7	8.0	9.0	7.5	8.5	9.3	8.0	8.8	8.4	24
26							4.2	6.7	7.8	6.2	7.2	8.2	6.8	7.5	7.1	26
28								4.5	6.7	5.2	6.2	7.1	5.7	6.5	6.1	28
30									3.3	4.4	5.3	6.2	4.9	5.6	5.2	30
32										2.1	4.6	5.5	4.1	4.9	4.5	32
34											3.9	4.8	3.5	4.2	3.8	34
36												4.2	2.9	3.7	3.2	36
38												2.1	2.4	3.2	2.7	38
40														2.7	2.3	40
42															1.9	42
44															1.6	44

\*Requires special equipment

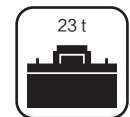

	12.9	17.5	19.9	22.2	24.5	26.8	29.1	31.5	33.8	36.1	38.4	40.7
	0°	0°	0°	0°	0°	0°	0°	0°	0°	0°	0°	0°
	10.4	15.1	17.4	19.7	22.0	24.3	26.6	29.0	31.3	33.6	36.0	38.0
	17.5	12.1	11.2	6.7	6.9	6.2	3.5	4.2	2.2	1.5	1.2	2.1

# LOAD CHARTS

## BOOM

ASME B30.5 85%

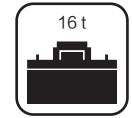
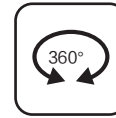

	12.9	17.5	19.9	22.2	24.5	26.8	29.1	31.5	33.8	36.1	38.4	40.7	43.0	45.4	50.0	
2.5	117*															2.5
3	110.0															3
4	85.0															4
5	70.0	70.0	39.2													5
6	58.5	58.5	40.3	55.0	37.5	39.2										6
7	49.0	49.0	41.3	47.5	38.6	40.0	37.0	30.1	28.0	31.0						7
8	42.5	42.2	42.1	40.3	39.1	37.5	37.0	30.5	26.3	30.5	22.5	20.6				8
9	37.0	35.7	37.1	34.1	36.5	35.2	35.0	28.0	24.7	27.5	21.6	19.8	19.5			9
10	25.0	29.9	33.0	29.4	32.0	33.1	31.0	26.5	23.4	27.6	20.4	18.7	18.9	17.4		10
12		20.3	23.1	19.9	22.2	24.1	21.6	22.4	21.2	22.7	18.5	17.2	17.3	17.0	13.9	12
14		14.7	17.2	14.3	16.5	18.1	15.9	17.4	18.7	16.8	16.6	15.2	15.7	15.9	13.4	14
16			13.4	10.7	12.6	14.2	12.1	13.5	14.7	13.0	14.1	13.5	13.6	14.1	12.4	16
18				8.0	9.9	11.5	9.4	10.8	11.9	10.3	11.3	12.2	10.8	11.7	11.2	18
20					7.9	9.4	7.4	8.7	9.8	8.2	9.2	10.2	8.8	9.6	9.1	20
22					5.0	7.8	5.9	7.2	8.2	6.6	7.6	8.6	7.2	8.0	7.5	22
24						4.8	4.6	5.9	6.9	5.4	6.4	7.3	5.9	6.7	6.3	24
26							2.5	4.9	5.9	4.4	5.3	6.2	4.9	5.6	5.2	26
28								3.1	5.0	3.5	4.5	5.4	4.0	4.8	4.3	28
30									2.9	2.7	3.7	4.6	3.3	4.0	3.6	30
32											3.1	4.0	2.7	3.4	3.0	32
34											2.5	3.4	1.9	2.9	2.4	34
36												3.0	1.4	2.4	1.9	36
38														1.9	1.4	38
40															1.0	40

\*Requires special equipment

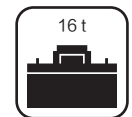

	12.9	17.5	19.9	22.2	24.5	26.8	29.1	31.5	33.8
	0°	0°	0°	0°	0°	0°	0°	0°	0°
	10.4	15.1	17.4	19.7	22.0	24.3	26.6	29.0	31.3
	15.5	9.9	9.3	4.3	5.0	4.5	2.2	2.9	1.6

**JIB**  
ASME B30.5 85%

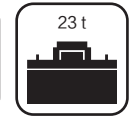
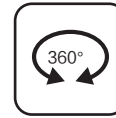

	50+10.8			
	0°	15°	30°	
16	6.2			16
18	6.1	5.3		18
20	6.0	5.1	3.5	20
22	6.0	5.1	3.3	22
24	5.4	4.9	3.2	24
26	4.6	4.6	3.1	26
28	4.0	4.2	3.0	28
30	3.4	3.6	2.9	30
32	3.0	3.2	2.7	32
34	2.5	2.7	2.6	34
36	2.2	2.3	2.5	36
38	1.9	2.0	2.2	38
40	1.6	1.7	1.8	40
42	1.4	1.4	1.5	42
44	1.1	1.3	1.3	44
46	0.9	1.0	1.1	46
48	0.7	0.8	0.9	48

# LOAD CHARTS

**JIB**  
**ASME B30.5 85%**

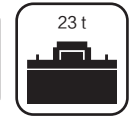
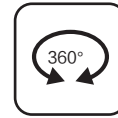

	50+18.3			
	0°	15°	30°	
18	3.0			18
20	3.1			20
22	3.1	2.4		22
24	3.1	2.2		24
26	3.1	2.1	1.6	26
28	2.9	2.0	1.5	28
30	2.8	1.9	1.4	30
32	2.7	1.8	1.3	32
34	2.6	1.7	1.2	34
36	2.4	1.6	1.2	36
38	2.2	1.5	1.1	38
40	1.8	1.4	1.1	40
42	1.6	1.4	1.0	42
44	1.4	1.3	1.1	44
46	1.2	1.2	1.0	46
48	1.0	1.2	1.0	48
50	0.8	1.0	1.0	50
52	0.6	0.8	0.9	52
54		0.7	0.8	54
56		0.5	0.6	56

**JIB**  
ASME B30.5 85%

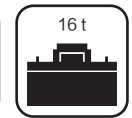

	50+10.8			
	0°	15°	30°	
16	6.2			16
18	6.1	5.3		18
20	5.9	5.1	3.5	20
22	5.0	5.1	3.3	22
24	4.1	4.5	3.2	24
26	3.5	3.8	3.1	26
28	2.9	3.2	3.0	28
30	2.4	2.7	2.9	30
32	2.1	2.3	2.4	32
34	1.7	1.9	2.1	34
36	1.4	1.5	1.7	36
38	1.2	1.3	1.4	38
40	0.9	1.0	1.2	40
42	0.7	0.8	0.9	42
44			0.7	44

# LOAD CHARTS

**JIB**  
**ASME B30.5 85%**

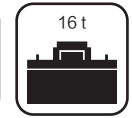
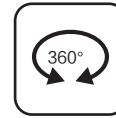

	50+18.3			
	0°	15°	30°	
18	3.0			18
20	3.1			20
22	3.1	2.4		22
24	3.1	2.2		24
26	3.1	2.1	1.6	26
28	2.9	2.0	1.5	28
30	2.7	1.9	1.4	30
32	2.3	1.8	1.3	32
34	2.0	1.7	1.2	34
36	1.6	1.6	1.2	36
38	1.4	1.5	1.1	38
40	1.2	1.4	1.1	40
42	0.9	1.2	1.0	42
44	0.7	1.0	1.1	44
46		0.7	0.9	46
48			0.7	48

**BOOM**

ASME B30.5 85%

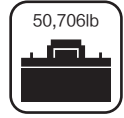

	42.3	57.4	65.3	72.8	80.4	87.9	95.5	103.3	110.9	118.4	126.0	133.5	141.1	148.9	164.0	
8.2	257938*															8.2
9.8	242506															9.8
13.1	198414															13.1
16.4	158731	154322	86420													16.4
19.7	132276	131174	88845	123458	82673	86420										19.7
23.0	114639	114639	91050	114639	85098	88184	81570	66358	61729	68343						23.0
26.2	100309	100309	93255	99207	86200	82673	81570	67240	57981	67240	49604	45415				26.2
29.5	85979	88845	88184	87302	88404	77602	77161	61729	54454	60627	47619	43651	42990			29.5
32.8	62831	77381	76720	76059	78263	72972	68343	58422	51588	60847	44974	41226	41667	38360		32.8
39.4		55776	60627	56438	62390	63272	59524	49383	46738	53792	40785	37919	38140	37478	30644	39.4
45.9		42108	46738	41887	46738	48722	44533	46958	42328	46517	36596	33510	34612	35053	29542	45.9
52.5			36376	31967	36596	38581	34392	37699	38581	36376	34171	29762	30864	31085	27337	52.5
59.1				24912	29321	31746	27337	30423	33069	29321	31746	26896	27778	27998	26455	59.1
65.6					23810	26676	22046	25132	27558	24030	26235	24471	25132	25353	23810	65.6
72.2					15212	22928	18078	20944	23369	19841	22046	22046	20944	22707	20944	72.2
78.7						14991	14771	17637	19841	16535	18739	20503	17637	19400	18519	78.7
85.3							9259	14771	17196	13669	15873	18078	14991	16535	15653	85.3
91.9								9921	14771	11464	13669	15653	12566	14330	13448	91.9
98.4									7275	9700	11684	13669	10803	12346	11464	98.4
105.0										4630	10141	12125	9039	10803	9921	105.0
111.5											8598	10582	7716	9259	8377	111.5
118.1												9259	6393	8157	7055	118.1
124.7												4630	5291	7055	5952	124.7
131.2														5952	5071	131.2
137.8															4189	137.8
144.4															3527	144.4

\*Requires special equipment

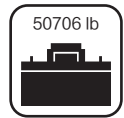
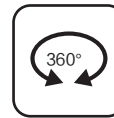
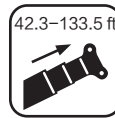

	42.3	57.4	65.3	72.8	80.4	87.9	95.5	103.3	110.9	118.4	126.0	133.5
	0°	0°	0°	0°	0°	0°	0°	0°	0°	0°	0°	0°
	34.1	49.5	57.1	64.6	72.3	79.8	87.4	95.2	102.8	110.3	118.1	124.7
	38581	26676	24692	14771	15212	13669	7716	9259	4850	3307	2646	4630

# LOAD CHARTS

## BOOM

ASME B30.5 85%

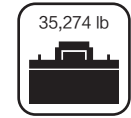
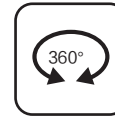

	42.3	57.4	65.3	72.8	80.4	87.9	95.5	103.3	110.9	118.4	126.0	133.5	141.1	148.9	164.0		
8.2	257938*															8.2	
9.8	242506															9.8	
13.1	187391															13.1	
16.4	154322	154322	86420													16.4	
19.7	128969	128969	88845	121253	82673	86420										19.7	
23.0	108025	108025	91050	104719	85098	88184	81570	66358	61729	68343						23.0	
26.2	93696	93034	92814	88845	86200	82673	81570	67240	57981	67240	49604	45415				26.2	
29.5	81570	78704	81791	75177	80468	77602	77161	61729	54454	60627	47619	43651	42990			29.5	
32.8	55115	65918	72752	64815	70547	72972	68343	58422	51588	60847	44974	41226	41667	38360		32.8	
39.4		44753	50926	43872	48942	53131	47619	49383	46738	50044	40785	37919	38140	37478	30644	39.4	
45.9		32408	37919	31526	36376	39903	35053	38360	41226	37037	36596	33510	34612	35053	29542	45.9	
52.5			29542	23589	27778	31305	26676	29762	32408	28660	31085	29762	29983	31085	27337	52.5	
59.1				17637	21826	25353	20723	23810	26235	22707	24912	26896	23810	25794	24692	59.1	
65.6					17416	20723	16314	19180	21605	18078	20282	22487	19400	21164	20062	65.6	
72.2					11023	17196	13007	15873	18078	14550	16755	18960	15873	17637	16535	72.2	
78.7						10582	10141	13007	15212	11905	14109	16094	13007	14771	13889	78.7	
85.3							5512	10803	13007	9700	11684	13669	10803	12346	11464	85.3	
91.9								6834	11023	7716	9921	11905	8818	10582	9480	91.9	
98.4									6393	5952	8157	10141	7275	8818	7937	98.4	
105.0											6834	8818	5952	7496	6614	105.0	
111.5												5512	7496	4189	6393	5291	111.5
118.1													6614	3086	5291	4189	118.1
124.7														4189	3086	124.7	
131.2															2205	131.2	

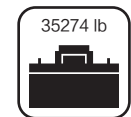

\*Requires special equipment



	42.3	57.4	65.3	72.8	80.4	87.9	95.5	103.3	110.9
	0°	0°	0°	0°	0°	0°	0°	0°	0°
	34.1	49.5	57.1	64.6	72.3	79.8	87.4	95.2	102.8
	34171	21826	20503	9480	11023	9921	4850	6393	3527

**JIB**  
**ASME B30.5 85%**



	164.0+35.4			
	0°	15°	30°	
52.5	13669			52.5
59.1	13448	11684		59.1
65.6	13228	11244	7716	65.6
72.2	13228	11244	7275	72.2
78.7	11905	10803	7055	78.7
85.3	10141	10141	6834	85.3
91.9	8818	9259	6614	91.9
98.4	7496	7937	6393	98.4
105.0	6614	7055	5952	105.0
111.5	5512	5952	5732	111.5
118.1	4850	5071	5512	118.1
124.7	4189	4409	4850	124.7
131.2	3527	3748	3968	131.2
137.8	3086	3086	3307	137.8
144.4	2425	2866	2866	144.4
150.9	1984	2205	2425	150.9
157.5	1543	1764	1984	157.5

# LOAD CHARTS

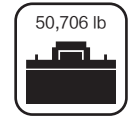
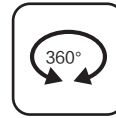
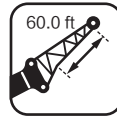

**JIB**  
**ASME B30.5 85%**



	164.0+60.0			
	0°	15°	30°	
59.1	6614			59.1
65.6	6834			65.6
72.2	6834	5291		72.2
78.7	6834	4850		78.7
85.3	6834	4630	3527	85.3
91.9	6393	4409	3307	91.9
98.4	6173	4189	3086	98.4
105.0	5952	3968	2866	105.0
111.5	5732	3748	2646	111.5
118.1	5291	3527	2646	118.1
124.7	4850	3307	2425	124.7
131.2	3968	3086	2425	131.2
137.8	3527	3086	2205	137.8
144.4	3086	2866	2425	144.4
150.9	2646	2646	2205	150.9
157.5	2205	2646	2205	157.5
164.0	1764	2205	2205	164.0
170.6	1323	1764	1984	170.6
177.2	1102	1543	1764	177.2
183.7		1102	1323	183.7

**JIB**  
ASME B30.5 85%



	164.0+35.4			
	0°	15°	30°	
52.5	13669			52.5
59.1	13448	11684		59.1
65.6	13007	11244	7716	65.6
72.2	11023	11244	7275	72.2
78.7	9039	9921	7055	78.7
85.3	7716	8378	6834	85.3
91.9	6393	7055	6614	91.9
98.4	5291	5952	6393	98.4
105.0	4630	5071	5291	105.0
111.5	3748	4189	4630	111.5
118.1	3086	3307	3748	118.1
124.7	2646	2866	3086	124.7
131.2	1984	2205	2646	131.2
137.8	1543	1764	1984	137.8
144.4			1543	144.4

# LOAD CHARTS

**JIB**  
**ASME B30.5 85%**

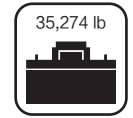
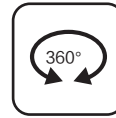

**164.0+60.0**















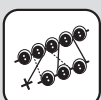





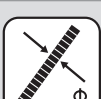



	164.0+60.0			
	0°	15°	30°	
59.1	6614			59.1
65.6	6834			65.6
72.2	6834	5291		72.2
78.7	6834	4850		78.7
85.3	6834	4630	3527	85.3
91.9	6393	4409	3307	91.9
98.4	5952	4189	3086	98.4
105.0	5071	3968	2866	105.0
111.5	4409	3748	2646	111.5
118.1	3527	3527	2646	118.1
124.7	3086	3307	2425	124.7
131.2	2646	3086	2425	131.2
137.8	1984	2646	2205	137.8
144.4	1543	2205	2425	144.4
150.9		1543	1984	150.9
157.5			1543	157.5

TYPE	ITEM	Unit	PARAMETERS			
Dimensions	Dimensions (L×W×H)	mm (ft)	15580×3490×3980 (51.1×11.4×13.1) CWT:16 t (35,274 lb)	15580×4700×3980 (51.1×15.4×13.1) CWT:23 t (50,706 lb)		
	Axle spacing	mm (ft)	4600(15.1)			
	Track (front / rear)	mm (ft)	2590(8.5) / 2590(8.5)			
	Front overhang / rear overhang	mm (ft)	2568(8.4)/2474(8.1)			
	Front extension / rear extension	mm (ft)	5922(19.4)/16(0.05)			
Weights	—		CWT:0 t (0 lb)	CWT:16 t (35,274 lb)	CWT:23 t (50,706 lb)	
	Axle load	Axle 1	kg (lb)	41,884 (92,338)	35,168 (77,532)	32,759 (72,220)
		Axle 2	kg (lb)	12,165 (26,819)	34,881 (76,899)	44,290 (97,643)
		Total	kg (lb)	54,049 (119,157)	70,049 (154,431)	77,049 (169,863)
Power	Engine model	—	Cummins L9, Teir 4f			
	Rated power	kW (bhp) / rpm	231(310) / 2100			
	Maximum output torque	N.m (ft-lb) / rpm	1526(1126) / 1400			
Travel	Maximum travel speed	km/h (mph)	≥30(18.6)			
	Minimum stable travel speed	km/h (mph)	1.8(1.2)			
	Minimum turning diameter	m (ft)	≤ 16.8(55.1)			
	Minimum turning diameter at boom tip	m (ft)	≤25.52(83.7)			
	Minimum ground clearance	mm (ft)	465(1.53)			
	Approach angle	°	21			
	Departure angle	°	22			
	Braking distance from 24kph (15mph)	m (ft)	≤9(29.5)			
Maximum gradeability	%	≥80				















# MAIN TECHNICAL PARAMETERS

CATEGORY	ITEM		UNIT	PARAMETERS	
Main performance	Maximum rated load lifting capacity		t (USt)	117(129)	
	Minimum rated working radius		m (ft)	2.5(8.2)	
	Turning radius at turntable tail	At the counterweight	mm (ft)	4890(16.0)	
	Maximum load moment	Base boom section		kN.m (ft-lb)	3567 (2,632,700)
		Fully-extended boom		kN.m (ft-lb)	2117 (1,562,480)
		Fully-extended boom + jib		kN.m (ft-lb)	1294 (955,050)
	Outrigger span	Longitudinal		m (ft)	8.45(27.7)
		Lateral		m (ft)	8.4/6.8/5.2/3.2 (27.6/22.3/17.1/10.6)
	Lifting height	Base boom		m (ft)	13.3(43.6)
		Fully-extended boom		m (ft)	49.8(163.3)
		Fully-extended boom + jib		m (ft)	64.8(212.5)
	Boom length	Base boom		m (ft)	12.9(42.3)
Fully-extended boom		m (ft)	50(164.0)		
Fully-extended boom + jib		m (ft)	68.3(224.0)		
Jib offset angle			°	0, 15, 30	
Working speeds	Time for raising boom		s	≤55	
	Time for fully extending the boom		s	≤125	
	Maximum slewing speed		rpm	≥1.8	
	Time for extending/ retracting outriggers	Outrigger beams	Retracting	s	≤40
			Extending	s	≤40
		Outrigger jacks	Retracting	s	≤55
			Extending	s	≤45
	Lifting speed (single line, no load)	Main winch system		m/min (fpm)	≥135(442.8)
Auxiliary winch		m/min (fpm)	≥90(295.2)		

	Superstructure
	Rated Lifting Load
	Counterweight
	Slewing Radius of Variable-position Counterweight
	Hook Block
	Parts of Line
	Boom Length Combination
	Wind Speed
	Configuration
	Optional Equipment
	Wire Rope Length
	Wire Rope Diameter

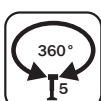
	Boom
	Boom Length
	Working Radius
	Lifting Height with Boom
	Boom Angle
	Extension
	Independent Jib Head
	Simple Jib Head
	Fixed Jib
	Fixed Jib Length
	Fixed Jib Offset Angle
	Luffing Jib

# DESCRIPTION OF SYMBOLS

	Maximum Single Line Pull		Maximum Lifting Height
	Maximum Working Speed		Maximum Working Radius
	Main Winch		Super Lift
	Auxiliary Winch		Wind Power Jib
	Chassis		Telescoping
	Outrigger Span		Slewing
	Tires		360° Slewing
	Axle Load		360° Slewing with the 5th Jack Down
	Gradability		Side and Rear Operation
	Travel Speed		Operation Over Front
	Luffing		Crane on Tires
	EN 13000 Standard		

**PARTS AND COMPLETE MACHINE TESTING**

- Every new technology and component must meet the most stringent design and quality protocols.
- Every complete machine undergoes rigorous run-in and testing, and components are subject to ongoing lifecycle testing.

**OVER 2,000 COMPONENTS FROM 123 MANUFACTURERS UNDERGOING LIFECYCLE TESTING**



HMI DISPLAY: LOW-TEMPERATURE PERFORMANCE TEST UNDER -40° C

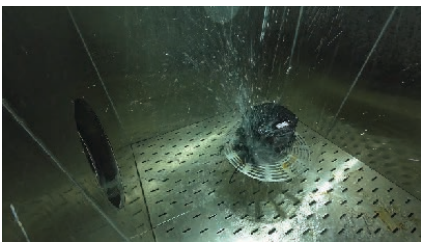

LENGTH MEASUREMENT SENSOR: 48-HOUR RAIN TEST



PANEL BUTTONS: CYCLED 12 MILLION TIMES

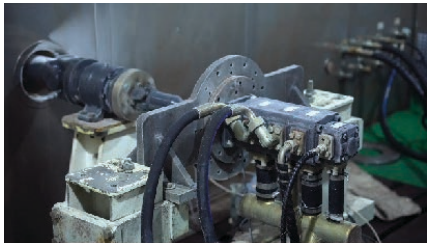

HYDRAULIC PUMP: LOW-TEMPERATURE PERFORMANCE TEST UNDER -40° C

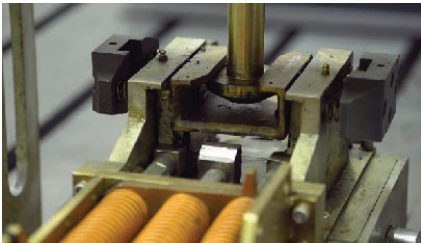

TELESCOPING MECHANISM: SMOOTHNESS TEST

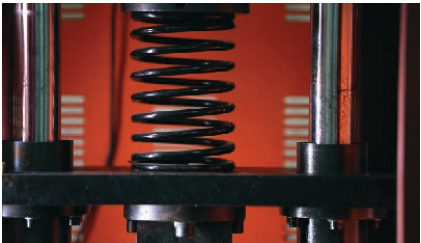

TELESCOPING MECHANISM: SMOOTHNESS TEST

**178 POST PRODUCTION FULL-SCALE TESTS ON THE COMPLETE MACHINE**



TERRAIN TESTING



CLIMBING AND HILL HOLDING



DYNAMIC AND STATIC LIFTING

# NOTES FOR LIFTING

- ❖ The total rated loads shown in the load charts reflect maximum lifting capacity when the crane is set up on firm, level ground with the tires clear of the ground. The weight of the hook block, rigging, and rope between the boom tip and block must be deducted, along with any optional equipment such as the auxiliary sheave and jib.
- ❖ The working radius shown in the load charts is measured at the point when the load is lifted off the ground, and reflects the actual value including loaded boom deflection. The operator must account for boom deflection before beginning any lift.
- ❖ Lifting operations are only permitted when wind speed is below 46.2 ft/s and wind pressure is below 2.59 lb/ft<sup>2</sup>.
- ❖ Before beginning a lift, the operator must know the weight of the load and the crane's working range, then select the appropriate working conditions. Never operate the crane beyond the limits shown in the chart. When the boom length or working radius falls between listed values, use the lower of the two. Always observe boom angle limits. Never exceed the recommended boom angle, even without a load, as doing so risks overturn.
- ❖ The boom must be extended according to the telescoping codes shown on the load charts.



Address: 305A Equipment Ct NE

Lawrenceville, GA 30046

Email: [cranes@xcmgusa.com](mailto:cranes@xcmgusa.com)

Website: [xcmg-usa.com/products/cranes-and-hoisting](http://xcmg-usa.com/products/cranes-and-hoisting)

## Do not copy without authorization!

This document is non-contractual. Constant improvement and engineering progress make it necessary that we reserve the right to make product model, specification and configuration changes without notice. Illustrations shown may include optional equipment and accessories and may not include all standard equipment. Some parts need to be purchased separately. Conform to the local laws for license application and road traveling.



XCMG  
North America