



All Rights Reserved

Materials and specifications are subject to change without notice.  
Featured machines in photos may include additional equipment.  
See your XCMG dealer for available options.



# CV83U/CV83PDU

## Single drum vibratory roller

EPA Tier 4F



[www.xcmg.com](http://www.xcmg.com)

**XCMG Regional Departments:**

Europe	(+86-516) 87739703 87739218 87739537	Africa	(+86-516) 87735009 87739222 87739283
West Asia & North Africa	(+86-516) 87739702 87739202 87739223	Central Asia	(+86-516) 87739236 87739239 87739538
Asia-Pacific	(+86-516) 87739128 87739500 87739529	America	(+86-516) 87739285 87739551 87739710

XUZHOU CONSTRUCTION MACHINERY GROUP IMP. & EXP. CO., LTD

Add: No.1, Tuolanshan Road, Xuzhou Economic Developing Zone, Jiangsu, China 221004

Fax: (+86-516) 87739230

E-mail: [export@xcmg.com](mailto:export@xcmg.com)



**Advanced Configuration**

**Superior power performance**

- ▶ Cummins engine, powerful and reliable
- ▶ Compliance with EPA Tier4F Emission standards



**Powerful driving ability**

- ▶ Efficient closed hydrostatic drive system
- ▶ Electro-hydraulic proportional controlled anti-skid system

**Excellent compaction performance**

- ▶ Dual frequency dual amplitude vibration system
- ▶ XCMG high rigidity drum
- ▶ Robust vibrating bearing

**Safe and ergonomic control platform**

- ▶ Spacious, all-around visibility cab
- ▶ Excellent vibration damping and noise insulation performance;
- ▶ High performance air conditioner

**Convenient maintenance**

- ▶ Real-time display working data on LCD display screen
- ▶ Large opening angle of engine hood, maintenance points within easy reach

**Superior power performance**



- ▶ CUMMINS QSF3.8 engine, 75Kw (100 HP) @ 2200 RPM;
- ▶ SCR after treatment device, fulfilling the requirements of EPA Tier 4F emission standards.
- ▶ High power radiator, applied to the high temperature region construction;
- ▶ Air pre-filter and air filter constitute two-stage filtration system;
- ▶ Fuel filter, oil filter and oil replacement cycle is up to 500 h;

**Strong driving ability**

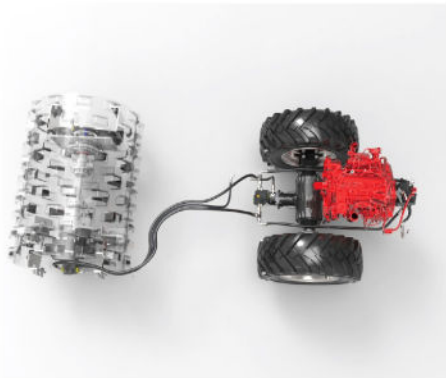

- ▶ Variable plunger pump and piston motor constitute the closed hydrostatic system; Heavy load wet drive axle;
- ▶ Anti-slip system ensures driving ability under toughest conditions;
- ▶ Two gear infinite variable speed;

**Excellent compaction performance**

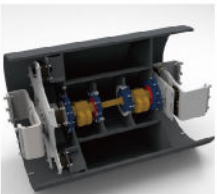

- ▶ DANFOSS plunger pump and piston motor constitute the hydrostatic vibration system;
- ▶ Double frequency, double amplitude, suitable for various construction conditions;
- ▶ Inner cylindrical vibrating chamber structure, high rigidity and strength.
- ▶ Dedicated vibration bearing, high reliability, long service life

**Safe and comfortable control platform**



- ▶ ROPS/FOPS cab. The interior space is large, wide vision, good sealing performance, low noise.
- ▶ Configuration of air conditioning further improves the driver's comfort;
- ▶ Air suspension seat. Good damping effect, fore and back, up and down adjustable;
- ▶ Electronic control joystick. Integrated vibration button, comfortable manipulation
- ▶ LCD Display. Real-time display the whole machine working state. Sound and light warning indicators on the instrument panel provide instant information on service and maintenance, preventing the machine from damages.



**Convenient maintenance**



- ▶ Engine hood is electronically controlled hydraulic open mode, easy to operate.
- ▶ Large opening angle of the engine hood, the maintenance area is within easy reach;

**Matching**

- ▶ Customer may, according to the requirements of the construction, choose smooth drum, padfoot drum and padfoot shell;
- ▶ Optional agriculture tire or diamond tire, meeting the demands of the various working conditions;



**Technical parameters**

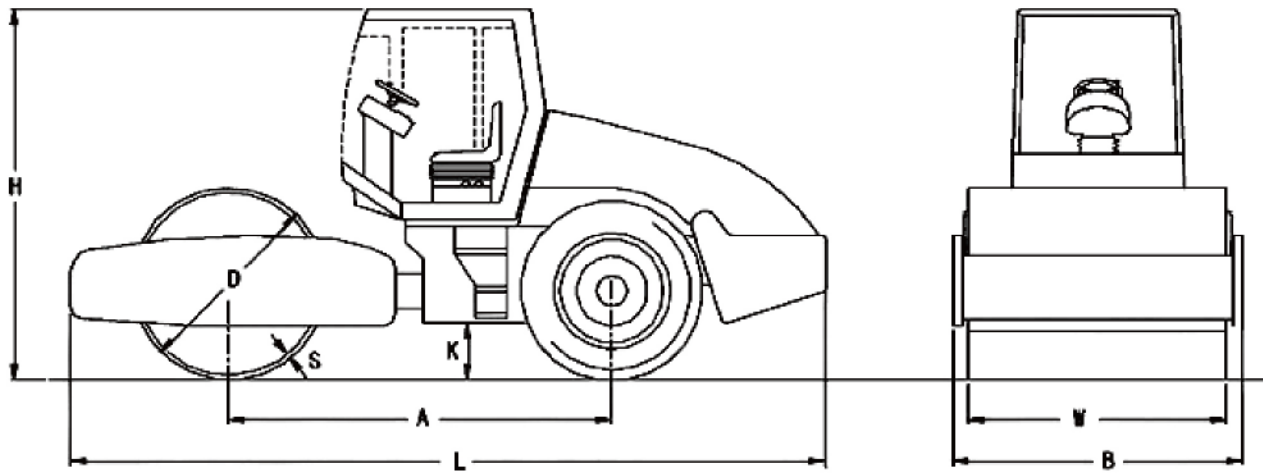

Size mm (in)	A	B	D	H	K	L	S	W
CV83U	2680 (105.5)	1860 (73.2)	1220 (48.0)	3040 (119.7)	270 (10.6)	5355 (210.8)	20 (0.8)	1680 (66.1)
CV83PDU	2680 (105.5)	1860 (73.2)	1220 (48.0)	3120 (122.8)	330 (13.0)	5355 (210.8)	20 (0.8)	1680 (66.1)

Item	Unit	Parameter and indexes	
		CV83U (Welded padfoot drum)	CV83PDU (Installed padfoot segment) (Welded padfoot drum)
Operating mass	kg(lb)	8000(17637.0)	Installed padfoot segment) 8730(19246.6)
			Welded padfoot drum 8430(18585.0)
Distributing mass of drum,	kg(lb)	3800(8377.6)	Installed padfoot segment) 4530(9986.9)
			Welded padfoot drum 4230(9325.6)
Distributed mass of rear drum	kg(lb)	4200(9259.4)	4200(9259.4)
Operating speed	km/h (mile/h)	0—5;0—11 (0—3.1;0—6.8)	0—5;0—11 (0—3.1;0—6.8)
Theoretical gradeability	%	50%	46%
Minimum turning radius	mm (ft)	5360(211.0)	5360(17.58)
Static linear load	kg/cm(pli)	22.6(127)	—

Compaction width	mm (in)	1680(66.1)	1680(66.1)
Nominal amplitude(High/Low),	mm (in)	1.8/0.9 (0.071/0.035)	1.5/0.75 (0.059/0.030)
Vibrational frequency(High/Low)	Hz(vpm)	30/35 (1800/2100)	30/35 (1800/2100)
Exciting force (High/Low)	kN(lbf)	125/85 (28100/19108)	125/85 (28100/19108)
Engine type		Cummins QSF3.8	Cummins QSF3.8
Engine power		75kW/2200rpm (100HP/2200rpm)	75kW/2200rpm (100HP/2200rpm)
Emission standard		EPA Tier 4F	EPA Tier 4F
Diesel tank volume	L(gal)	200(52.8)	200(52.8)
Hydraulic tank volume	L(gal)	200(52.8)	200(52.8)
Overall Dimension (Length × Width × Height)	mm(ft)	5355 × 1860 × 3040 (17.57 × 6.10 × 9.97)	5360 × 1860 × 3120 (17.58 × 6.10 × 10.24)