



BOOM TRUCK XCT40_U

Less Flex, More Lift

 40 USt

 142 ft

 112 ft

 197 ft





CONTENTS

Product Advantages and Highlights	01-03
Dimensions	04-05
Technical Specifications	06-07
Boom / Jib Combinations	08
Working Range Diagram and Load Charts	09-14
Working Areas and Reeving Diagram	15
Table of Main Technical Parameters	16-17
Description of Symbols	18-19



INDUSTRY LEADING PERFORMANCE

SUPERB LIFTING PERFORMANCE

- The 5-section U-shaped boom extends to 142 ft, matching the longest reach in the 40-ton class with less deflection and a stronger structure under load than a conventional box boom.
- Dual-cylinder wire-rope telescoping keeps extension and retraction synchronized.
- An optional three jib offset angles at 0°, 15°, and 30° across a 30.5 ft to 53.5 ft bi-fold jib provide greater operational flexibility.



HIGH WORKING EFFICIENCY SUPERIOR STABILITY

- Fast when the job demands speed. Precise when the lift demands control. Dual load sense variable displacement pumps with pilot controls deliver both.
- Minimum stable winch speed of 8.2 fpm and minimum stable slewing speed of 0.1°/s for pinpoint load placement.
- Hydraulic pilot controls for responsive operation.
- Smooth, controlled performance built for surgical lifting without sacrificing productivity.

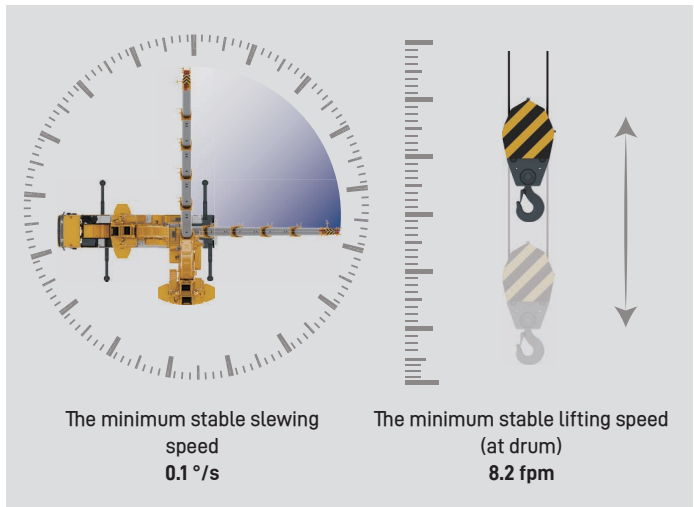

ADVANCED HYDRAULIC SYSTEM

- Energy-saving hydraulic system improves fuel efficiency and reduces operating costs.
- High-power independent hydraulic oil cooling system extends working time and reliability.
- Dual-pump combined/divided flow control with high-displacement pumps and active compensation technology improves hoisting efficiency.

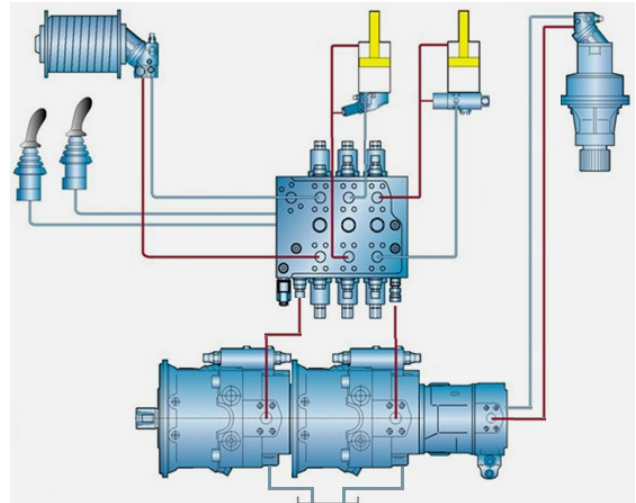

OUTRIGGER WIRELESS REMOTE CONTROL

- Wireless outrigger deployment within a 328 ft range.

MAIN WINCH LUFFING WIRELESS REMOTE CONTROL

- Wireless control of main winch hoisting and luffing operations. Built for a one-man crew.

SMART LIFT PLANNING

- The onboard system automatically recommends the best operating mode for the task.
- Search, select, and set working conditions in seconds. Less time planning the lift, more time making it.

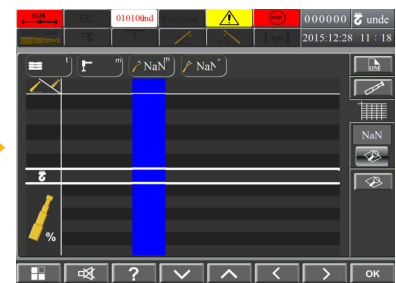
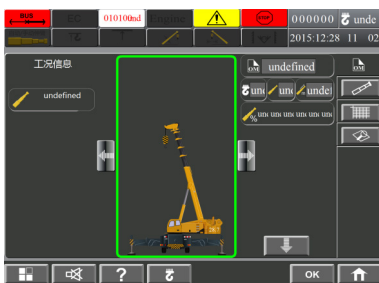

COMFORT-DRIVEN CAB DESIGN



Redesigned driver and operator cab interiors put comfort and control where they should be, within reach. Every switch, sight line, and access point built around how operators actually work. Easier drives. Smoother operations. Faster maintenance.

Operator's Cab	0°–20° tiltable cab for wider visibility and a comfortable, purpose-built workspace.
Touchscreen	7-inch true-color touchscreen puts key information and machine intelligence at the operator's fingertips. Easy to learn, logical to anyone who's run a crane.
Zoned Controls	Three dedicated control zones for safety, lifting, and operating to keep everything within reach.

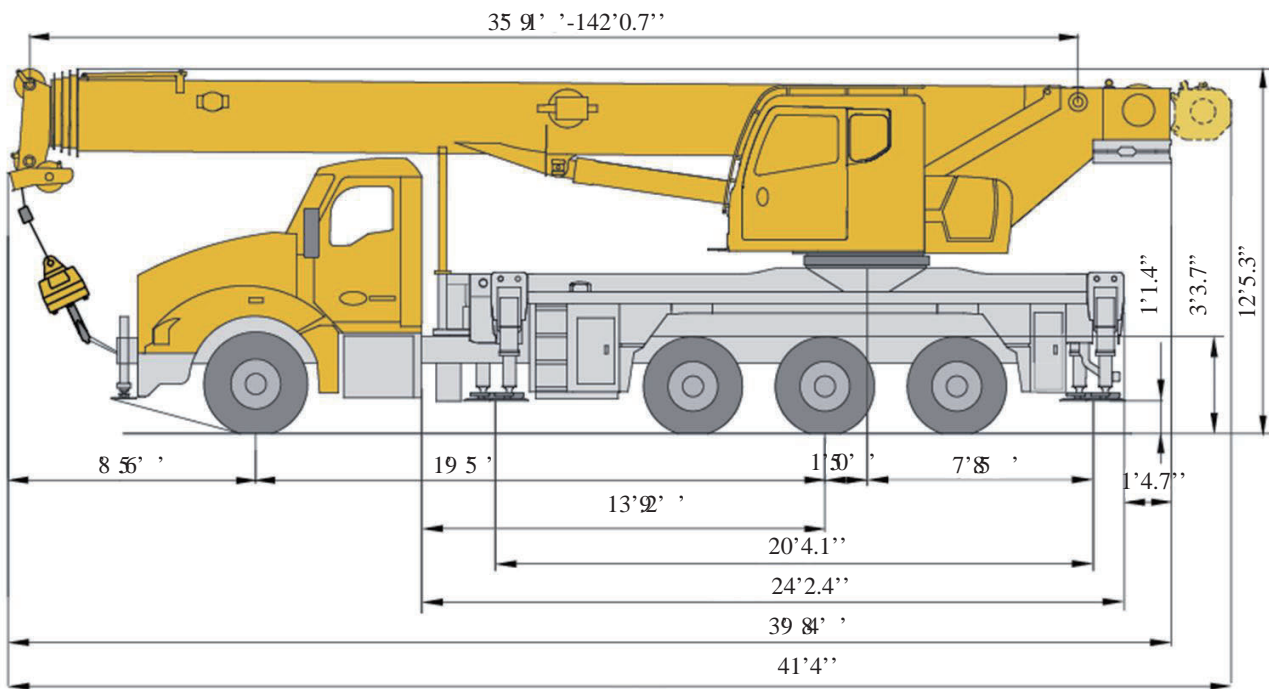

CHASSIS DATA	FRONT AXLE GROSS WEIGHT RATING	REAR AXLE GROSS WEIGHT RATING	PUSHER AXLE WEIGHT RATING
Weight	22,000 lb	46,000 lb	13,500 lb



	CRANE (STANDARD)	FIX JIB	AUXILIARY WINCH (INCLUDING ROPE)
Weight	45,465 lb	1,880 lb	1,220 lb



HOOK BLOCKS	NO. OF SHEAVES	PARTS OF LINE	WEIGHT	REMARKS
40 Ust	4	8	794 lb	Single hook
27.5 Ust	3	6	440 lb	Single hook
15 Ust	1	3	400 lb	Single hook
5.5 Ust	—	1	220 lb	Single hook

DIMENSIONS

Fully Extended

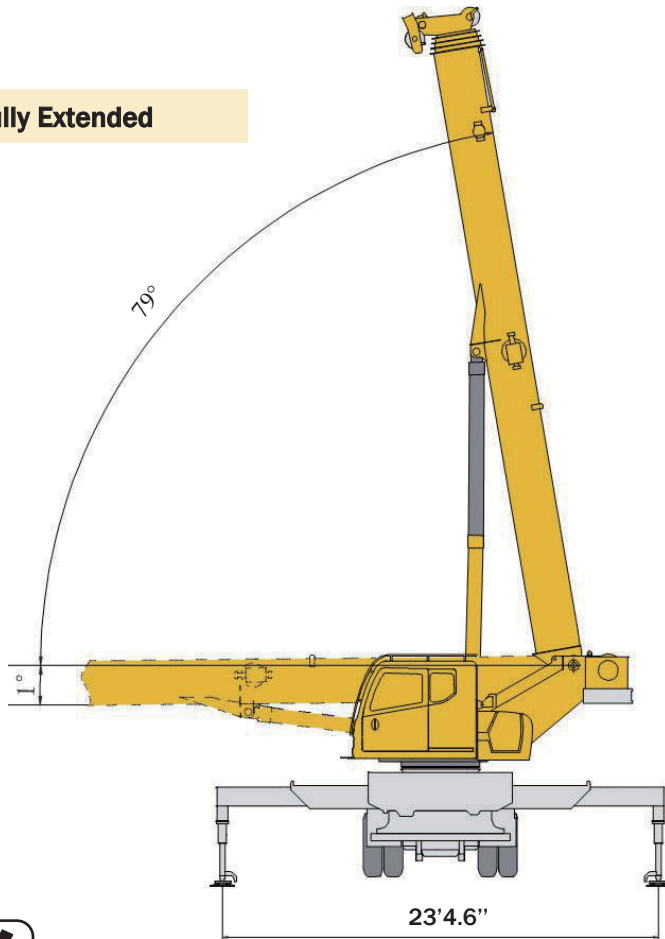

Half Extended

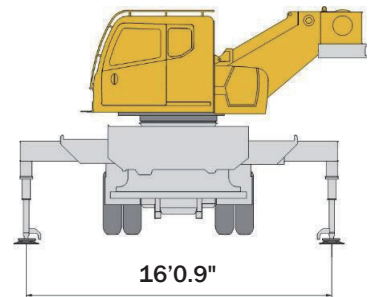

WORKING SPEEDS

MAXIMUM SINGLE LINE PULL

ROPE DIAMETER/ LENGTH



0-394 fpm, Single line, 4th layer

11,023 lb

0.63 in / 410 ft



0-394 fpm, Single line, 4th layer

11,023 lb

0.63 in / 423 ft



0-1.2 r/min



Approximately 35s for boom elevation from -1° to 79°



Approximately 70s for boom extension from 35.8 ft to 142 ft

	INTERMEDIATE FRAME
Subframe	Designed and manufactured by XCMG, with all covered walking surface, made of high strength steel with inverted trapezoid cross section.
Outriggers	H-type outrigger beams with 4-point supported are wireless controlled. Wireless remote controller is standardly equipped. There is a mechanical control outrigger panel installed at rear side of chassis, with level gauge to level crane. The outrigger leg is stored under the outrigger jack with the ball hinge device. Fully-extended: 20.3 ft×23.6 ft Half-extended: 20.3 ft×16 ft
Hydraulic System	The hydraulic system of outriggers is a constant displacement open-circuit system. The variable piston pump is connected to the transmission through PTO.

	SUPERSTRUCTURE
Subframe	Designed and manufactured by XCMG, made of high-strength steel.
Hydraulic System	Variable plunger pump is used for lifting, elevating, and telescoping; the gear plunger pump is used for slewing; load-sensing proportional multi-way directional control valve controlled by electric proportional pilot hydraulic oil is adopted; air-cooled hydraulic oil radiator is applied, which effectively reduces oil temperature of the system. Effective volume of oil tank: 149 gal
Control System	Pilot hydraulic proportional control is available. CAN bus power limit control system. In addition to the conventional control function, it also has the lifting planning, engine parameter virtual instrument display, fault diagnosis, etc.
Main Winch System	Hydraulic control is used for speed regulation. The system is driven by a hydraulic motor through a planetary gear reducer, with a normally closed brake, a balanced valve and a grooved drum equipped.
Operator's Cab	New fully-enclosed steel tiltable cab with a full-view front window. Safety glass and sun screen are used for windows. Wipers are fitted for windshield and roof window. Standard controls and indicators are ergonomically arranged in the cab. The cab features a new ergonomic seat design with backrest adjustment and armrests with levers fitted. A sliding door and a pull-out step are available to make it easy and safe as access and egress the cab.
Slewing System	Hydraulic control is used for speed regulation. The system is driven by a hydraulic motor through a planetary gear reducer, with a normally closed brake, a balanced valve and a grooved drum equipped.
Safety Devices	Hydraulic balance valve, Hydraulic relief valve, Double-way hydraulic valve, LMI. Lowering limiter for preventing wire rope from over-releasing. Anti-two block at boom head for preventing wire rope from over-winding.
LMI	The LMI is installed in the control box with its display mounted in the operator's cab. When actual moment approaches overload value, it may send out visual alarm, automatically stop dangerous movements before overloading. Overload memory function (black box) and fault self-diagnosis function are available.
Counterweight	Total weight is 4409 lbs, fixed counterweight.
Hook Blocks	5.5 USt

TECHNICAL SPECIFICATIONS

BOOM SYSTEM	
Boom	5-section, U-shape cross section welding structure. The double-cylinder plus ropes telescoping system. Two double-acting cylinders with safe valve assemblies used for control of the telescoping movement of all booms. Boom length: 35.8 ft ~ 142 ft Boom angle: -1° ~ 79°
Auxiliary sheave	Fitted at boom head, used for 8 parts of line and single line operation. Its lifting performance is the same as that for boom, but the maximum lifting load could not exceed 11,023 lbs.
OPTIONAL EQUIPMENT	
Auxiliary Winch System	Hydraulic control is used for speed regulation. The system is driven by a hydraulic motor through a planetary gear reducer, with a normally closed brake, a counterbalance valve and a grooved drum equipped.
Jib	The jib consists of a connecting bracket, a mechanical link and two lattice sections. Three offset angles of 0°, 15° and 30° are available. Jib length: 30.5 ft, 53.5 ft
Hook Blocks	40 USt, 27.5 USt, 15 USt
Fifth Jack	By adding the 5th jack, 360° full slewing operation is available
Nylon Outrigger Pad	Including an outrigger pad storage box and five nylon outrigger pads, which increase the contact area with the ground to provide stable support and ensure operational safety.
Fixing Device of Hook Block	The middle hook can be secured to the auxiliary frame to prevent it from obstructing the forward driving visibility.
Wireless Boom Head Camera (Outside the Boom)	Wireless zoom camera monitors the status of the boom head, expanding the operator's field of view.
Turntable Locking Device	During superstructure operation, the slewing mechanism can be locked at any position during slewing.
Wireless Remote Control Optional Package	The crane's luffing and main winch up/down are operated by wireless remote control.

Please refer to the product quotation for specific parts.

BOOM	BOOM + ONE JIB SECTION	BOOM + TWO JIB SECTIONS
T: 35.8~142 ft	T: 142 ft J: 30.5 ft	T: 142 ft J: 30.5~53.5 ft





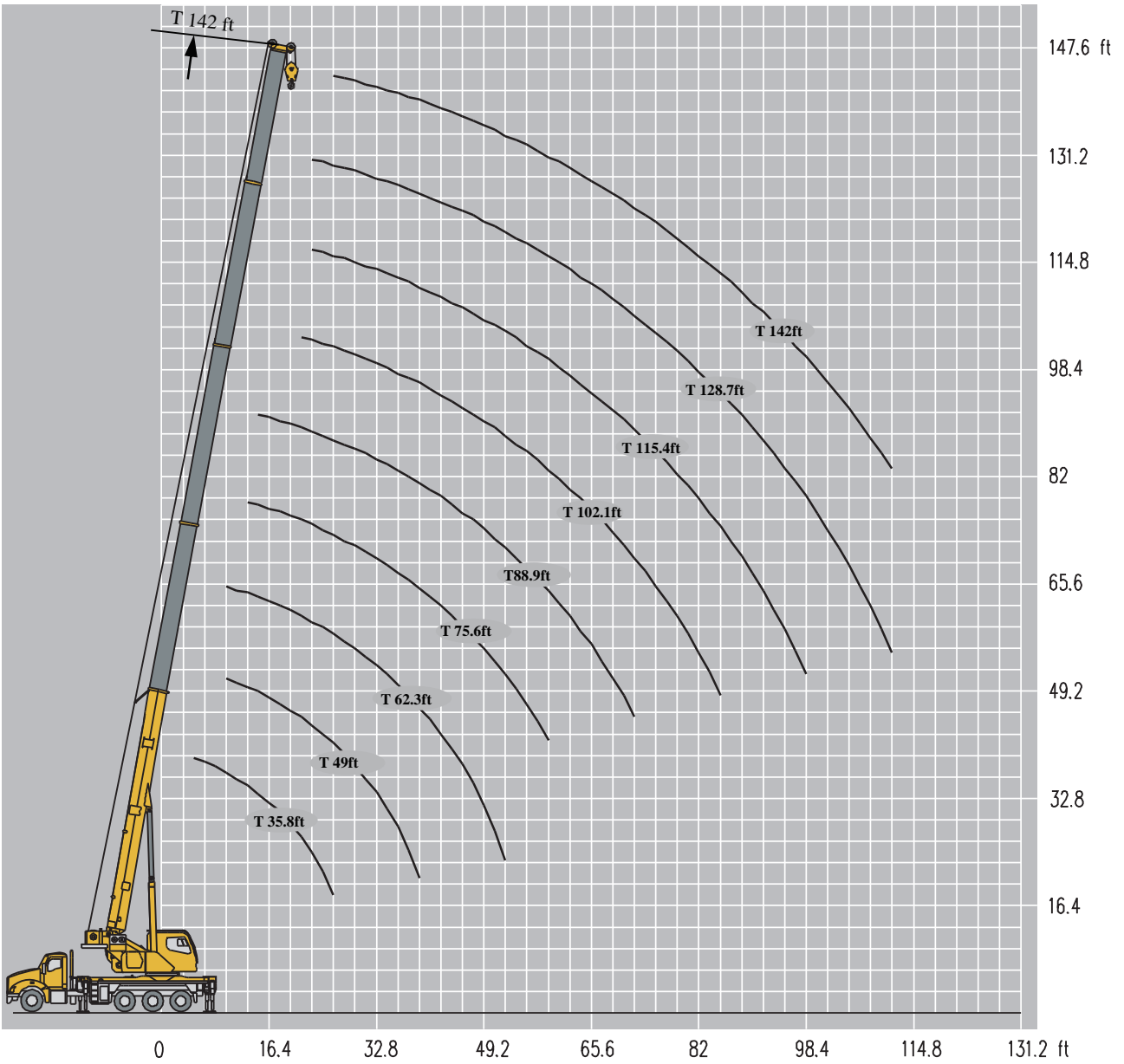

WORKING RANGE DIAGRAM

BOOM

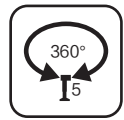

T 35.8~142ft





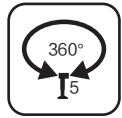
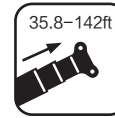

	35.8 ft	49 ft	49 ft	62.3 ft	62.3 ft	62.3 ft	75.6 ft	75.6 ft	75.6 ft	88.9 ft	88.9 ft	
5	80020											5
7	70540											7
8	61720											8
10	55110	30860	44090	30860	28210	39680						10
11	55110	30860	44090	30860	28210	39680						11
13	49600	30860	43870	30860	28210	39680	28210	18950	30860			13
15	46290	30860	43650	30860	28210	39680	28210	18950	30860	18950	13880	15
16	43210	30860	40560	30860	28210	38580	28210	18950	30860	18950	13880	16
18	39020	30860	37910	30860	28210	35710	28210	18950	30860	18950	13880	18
20	34830	30860	35050	30860	28210	33500	28210	18950	30860	18950	13880	20
21	31740	29760	30860	30860	28210	30860	28210	18950	30420	18950	13880	21
23	29100	29100	28650	29760	28210	27330	28210	18950	28880	18950	13880	23
26	24250	26450	24250	25350	26450	23140	26010	18950	24690	18950	13880	26
30		22480	20500	22040	22700	19840	22040	18950	19840	18950	13880	30
33		20500	18070	19400	20500	17410	20280	18950	18730	18950	13880	33
36		17630	15210	16530	17410	14320	16970	18510	15430	17850	13880	36
39		14990	12780	13880	14990	12120	14770	16090	13220	15430	13880	39
43				12120	12780	10360	12780	14100	11240	13220	13880	43
46				10360	11240	8590	11240	12340	9700	11680	12780	46
49				9030	9920	7270	9700	11020	8370	10360	11460	49
52				7930	8810	6170	8590	9920	7050	9030	10140	52
59							6610	7930	5290	7050	8150	59
66										5730	6830	66
72										4620	5510	72
	0	0%	50%	50%	0	100%	50%	0	100%	50%	0	
	0	16.70%	0%	16.70%	33.30%	0	33.30%	50%	16.70%	50%	66.70%	
	0	16.70%	0%	16.70%	33.30%	0	33.30%	50%	16.70%	50%	66.70%	
	0	16.70%	0%	16.70%	33.30%	0	33.30%	50%	16.70%	50%	66.70%	

LOAD CHARTS

T 35.8 ~ 142 ft



	88.9 ft	102.1 ft	102.1 ft	102.1 ft	115.4 ft	115.4 ft	115.4 ft	128.6 ft	128.7 ft	142 ft	
15	28210										15
16	27550										16
18	26890										18
20	25350										20
21	24250	13880	10360	18950							21
23	23360	13880	10360	18070	10360	8370	13880	8370	10360		23
26	21820	13880	10360	16750	10360	8370	13880	8370	10360	8370	26
30	20280	13880	10360	15650	10360	8370	13220	8370	10360	8370	30
33	18070	13880	10360	14770	10360	8370	13000	8370	10360	8370	33
36	16530	13880	10360	14100	10360	8370	12780	8370	10360	8370	36
39	14320	13880	10360	13440	10360	8370	12560	8370	10360	8370	39
43	12120	13220	10360	12560	10360	8370	11680	8370	10360	8370	43
46	10580	12120	10360	11020	10360	8370	10800	8370	10140	8150	46
49	9250	10800	10360	9700	10360	8370	9700	8370	9250	7930	49
52	8150	9470	10140	8370	9700	8370	8810	7930	8590	7490	52
59	5950	7490	8370	6610	7710	7710	6830	7710	7270	6390	59
66	4620	5950	7050	5070	6390	7050	5510	6610	5730	5950	66
72	3300	4850	5510	3960	5070	5950	4180	5290	4620	4850	72
79		3960	4850	2860	4180	5070	3300	4400	3520	3740	79
85		3080	3740	1980	3300	4180	2420	3520	2640	2860	85
92					2640	3520	1540	2860	1980	2200	92
98					1980	2640	1100	1980	1320	1540	98
105								1540	880	1100	105
112								1100		660	112
	100%	50%	0	100%	50%	0	100%	50%	100%	100%	
	33.30%	66.70%	83.30%	50%	83.30%	100%	66.70%	100%	83.30%	100%	
	33.30%	66.70%	83.30%	50%	83.30%	100%	66.70%	100%	83.30%	100%	
	33.30%	66.70%	83.30%	50%	83.30%	100%	66.70%	100%	83.30%	100%	

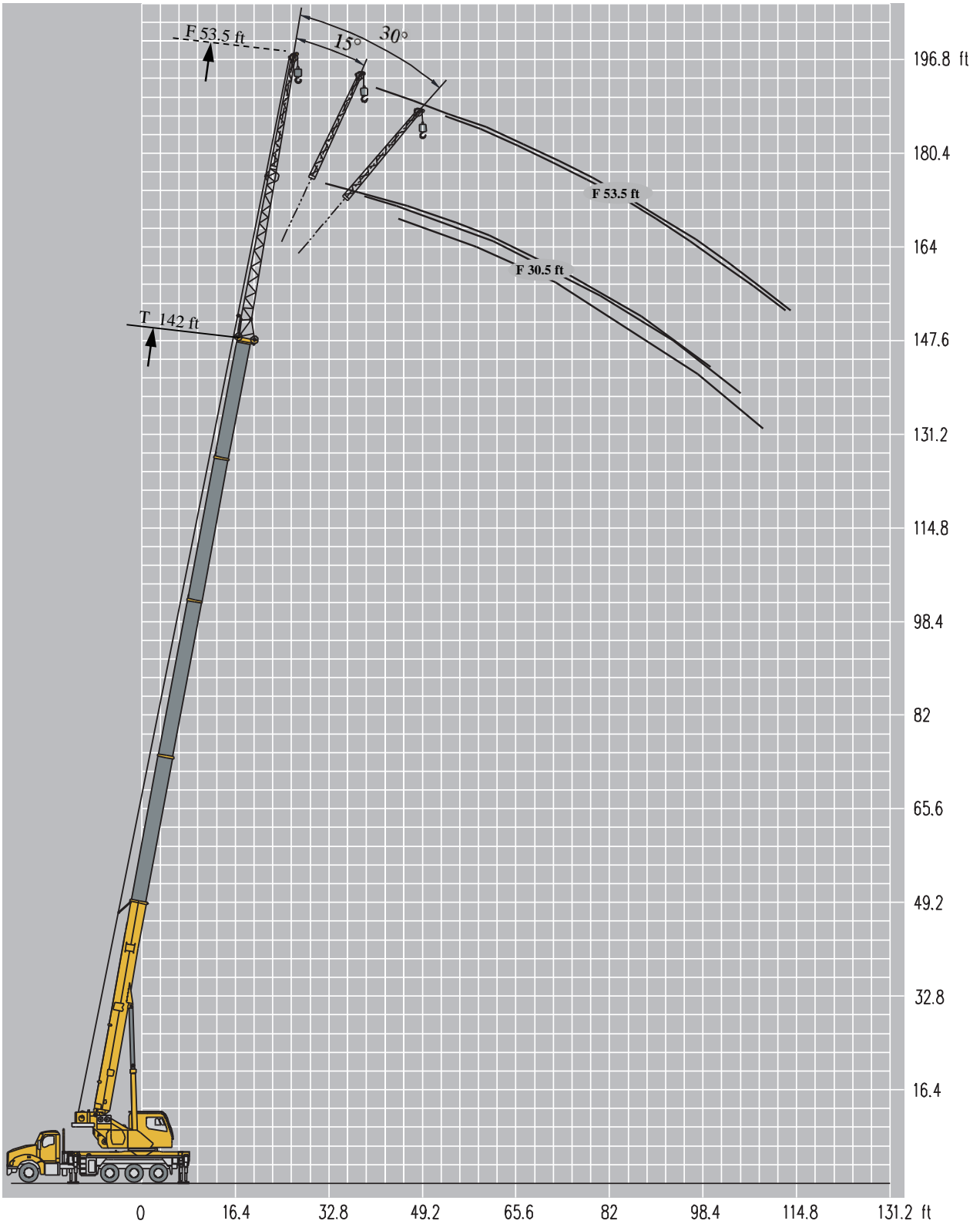

JIB

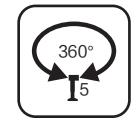
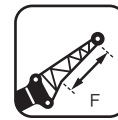
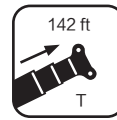

LOAD CHARTS

T 142 ft



	142 ft			142 ft		
	30.5 ft			53.5 ft		
	0°	15°	30°	0°	15°	
79	3740	3300	2640	2200	1100	79
78	3520	3260	2640	1980	1050	78
75	3190	3190	2640	1870	990	75
72	3080	3080	2420	1650	880	72
70	2860	2860	2420	1540	880	70
65	2750	2640	2420	1320	770	65
60	2640	2420	2200	1100	660	60
55	1760	1540	1540	770		55
50	880					50

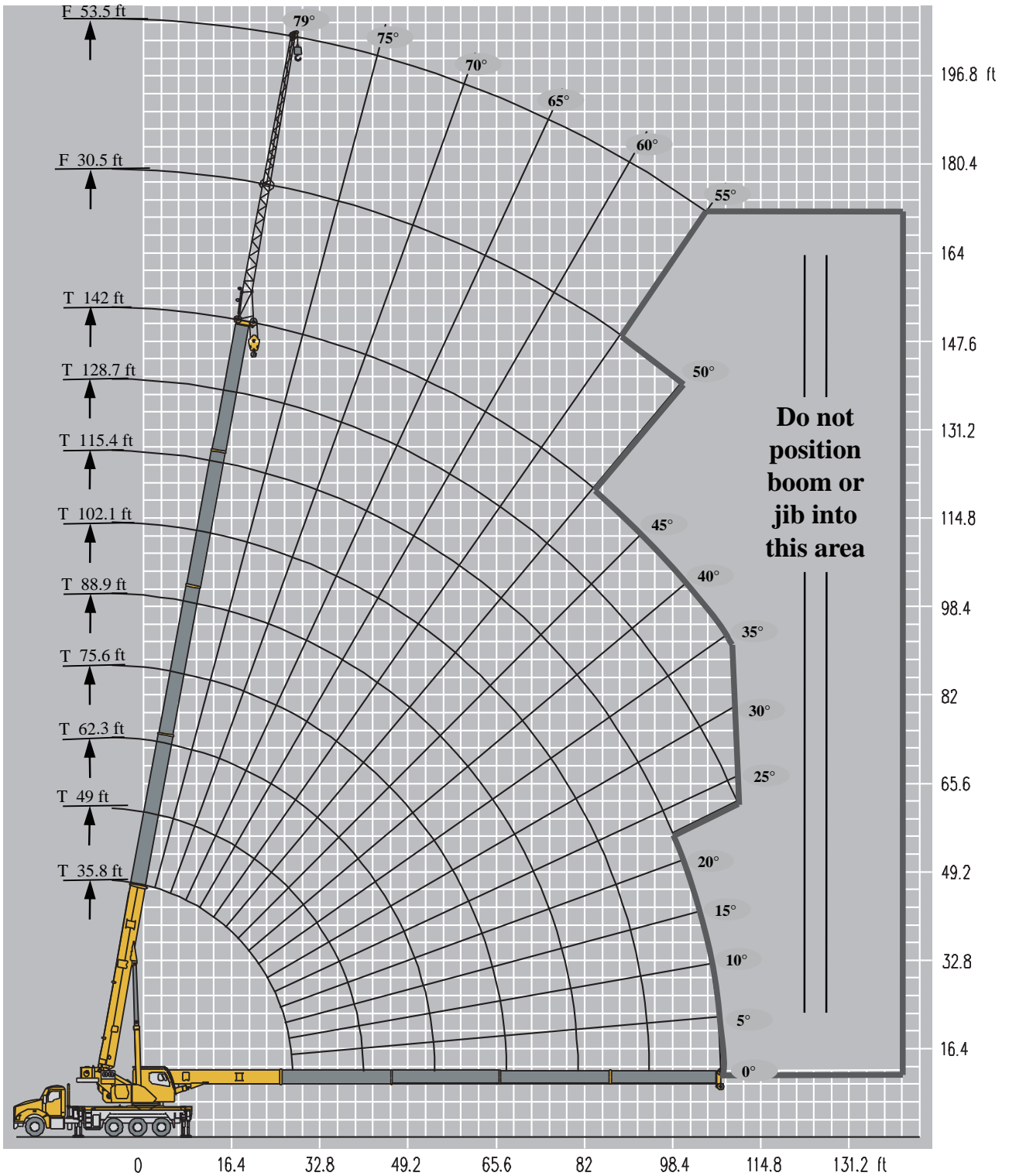

WORKING AREAS

In order to take advantage of full 360° rotation, the fifth jack must be set in accordance with the manual before working in this area, and the machine must be level. If the fifth jack is lowered, the crane can only be operated with the boom over the side or over the rear of the crane.

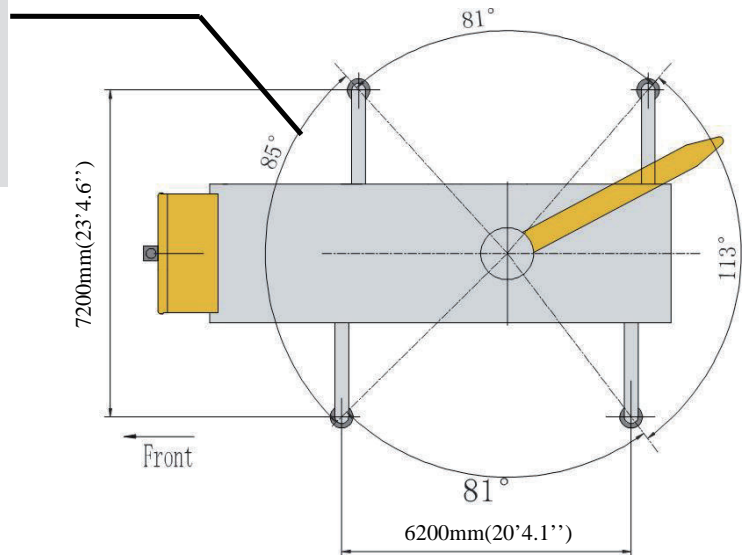











REEVING DIAGRAM



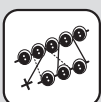





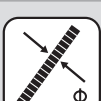

ALLOWABLE LINE PULL								WARNING
8 parts of line	7 parts of line	6 parts of line	5 parts of line	4 parts of line	3 parts of line	2 parts of line	1 part of line	
								Refer to the owners manual
								Incorrect reeving or incorrect input of parts of line may result in serious accidents.
								Keep at least three turns of rope left on
82,252 lb	72,683 lb	62,913 lb	52,954 lb	42,787 lb	32,412 lb	21,826 lb	11,023 lb	—

CATEGORY	ITEM		UNIT	PARAMETER
Dimensions	Overall length		ft	476.4
	Overall width		ft	98.4
	Overall height		ft	149.3
	Axle spacing		ft	179+54+54
	Track		ft	82.2/84.4/73.3/73.3
Weights	Total vehicle weight in travel configuration		lb	66100
	Axle load	Axle 1	lb	18400
		Axle 2	lb	12150
		Axles 3-4 (in tandem)	lb	35550
Power	Chassis engine model		/	MX-13
	Rated power/rpm		HP/(rpm)	455/1700
	Maximum output torque/rpm		lb-ft/(rpm)	1650/1000-1500
Travel	Maximum travel speed		mile/h	65
	Minimum turning diameter		ft	78.8
	Minimum turning diameter of boom head		ft	85.3
	Minimum ground clearance		in	12
	Approach angle		°	16
	Departure angle		°	13

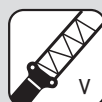













TABLE OF MAIN TECHNICAL PARAMETERS

CATEGORY	ITEM		UNIT	PARAMETER	
Main Performance	Maximum rated lifting capacity		USt	40	
	Minimum rated working radius		ft	5	
	Turning radius at turntable tail (at counterweight)		ft	10.43	
	Maximum load moment	Base boom	lb-ft	702000	
		Fully-extended boom	lb-ft	393000	
		Fully-extended boom + jib	lb-ft	231000	
	Outrigger span (fully-extended)	Longitudinal	ft	20.3	
		Lateral	ft	23.6	
	Lifting height	Base boom	ft	37	
		Fully-extended boom	ft	141	
		Fully-extended boom + jib	ft	197	
	Boom length	Base boom	ft	35.8	
		Fully-extended boom	ft	142	
Fully-extended boom + jib		ft	195.5		
Jib offset angle		°	0, 15, 30		
Working Speeds	Time for raising boom		s	35	
	Time for fully extending boom		s	70	
	Maximum slewing speed		rpm	1.2	
	Time for extending and retracting outriggers	Outrigger beams	Extending	s	≤35
			Retracting	s	≤35
		Outrigger jacks	Extending	s	≤40
			Retracting	s	≤40
Lifting speed (single line, 4th layer, no load)	Main winch system	fpm	394		

	Superstructure
	Rated Lifting Load
	Counterweight
	Slewing Radius of Variable-Position Counterweight
	Hook Block
	Parts of Line
	Boom Length Combination
	Wind Speed
	Configuration
	Optional Equipment
	Wire Rope Length
	Wire Rope Diameter

	Boom
	Boom Length
	Working Radius
	Lifting Height with Boom
	Boom Angle
	Extension
	Independent Jib Head
	Simple Jib Head
	Fixed Jib
	Fixed Jib Length
	Fixed Jib Offset Angle
	Luffing Jib

DESCRIPTION OF SYMBOLS

	Maximum Single Line Pull		Maximum Lifting Height
	Maximum Working Speed		Maximum Working Radius
	Main Winch		Super Lift
	Auxiliary Winch		Wind Power Jib
	Chassis		Telescoping
	Outrigger Span		Slewing
	Tires		360° Slewing
	Axle Load		360° Slewing with the 5th Jack Down
	Gradeability		Side and Rear Operation
	Travel Speed		Operation Over Front
	Luffing		Operation Over Rear
	EN 13000 Standard		Luffing Jib Winch

TESTED AT EVERY LEVEL

- Each new technology and component is required to meet the most stringent design and quality protocols.
- Each complete machine undergoes rigorous run in and testing, components are subject to ongoing testing.

OVER 2,000 COMPONENTS FROM 123 MANUFACTURERS UNDERGOING LIFE CYCLE TESTING



HMI Display: Low-Temperature Performance Test Under -40°C

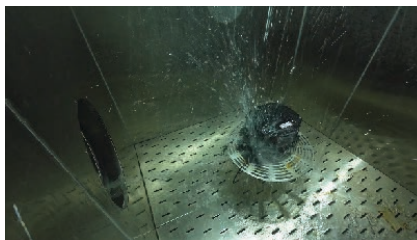

Length Measurement Sensor: 48-Hour Rain Test



Panel Buttons: Cycled 12 Million Times

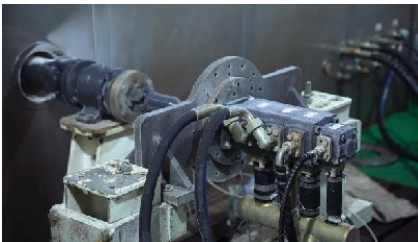

Hydraulic Pump: Low-Temperature Performance Test Under -40°C

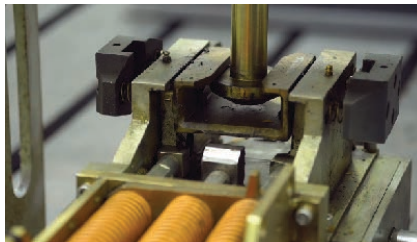

Telescoping Mechanism: Smoothness Test

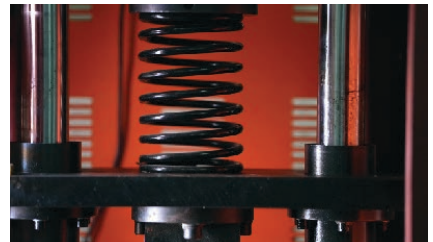

Telescoping Mechanism: Smoothness Test

178 POST-PRODUCTION FULL-SCALE TESTS ON EVERY COMPLETE MACHINE



Dynamic & Static Lifting



Terrain Testing



Climbing & Hill Holding

NOTES FOR LIFTING

The total rated loads shown in the load charts reflect maximum lifting capacity when the crane is set up on firm, level ground with the tires clear of the ground. The weight of the hook block, rigging, and rope between the boom tip and block must be deducted, along with any optional equipment such as the auxiliary sheave and jib.

The working radius shown in the load charts is measured at the point when the load is lifted off the ground, and reflects the actual value including loaded boom deflection. The operator must account for boom deflection before beginning any lift. Lifting operations are only permitted when wind speed is below 46.2 ft/s and wind pressure is below 2.59 lb/ft².

Before beginning a lift, the operator must know the weight of the load and the crane's working range, then select the appropriate working conditions. Never operate the crane beyond the limits shown in the chart. When the boom length or working radius falls between listed values, use the lower of the two. Always observe boom angle limits. Never exceed the recommended boom angle, even without a load, as doing so risks overturn.

The boom must be extended according to the telescoping codes shown on the load charts.



Address: 305A Equipment Ct NE

Lawrenceville, GA 30046

Email: cranes@xcmgusa.com

Website: xcmg-usa.com/products/cranes-and-hoisting/

Do not copy without authorization!

This document is non-contractual. Constant improvement and engineering progress make it necessary that we reserve the right to make product model, specification and configuration changes without notice. Illustrations shown may include optional equipment and accessories and may not include all standard equipment. Some parts need to be purchased separately. Conform to the local laws for license application and road traveling.



American
Crane
Products



XCMG
North America